

**PROJECT WBS: 17BP.10.R.63**

See Sheet 1-A For Index of Sheets  
See Sheet 1-B For Standard Symbology Sheet

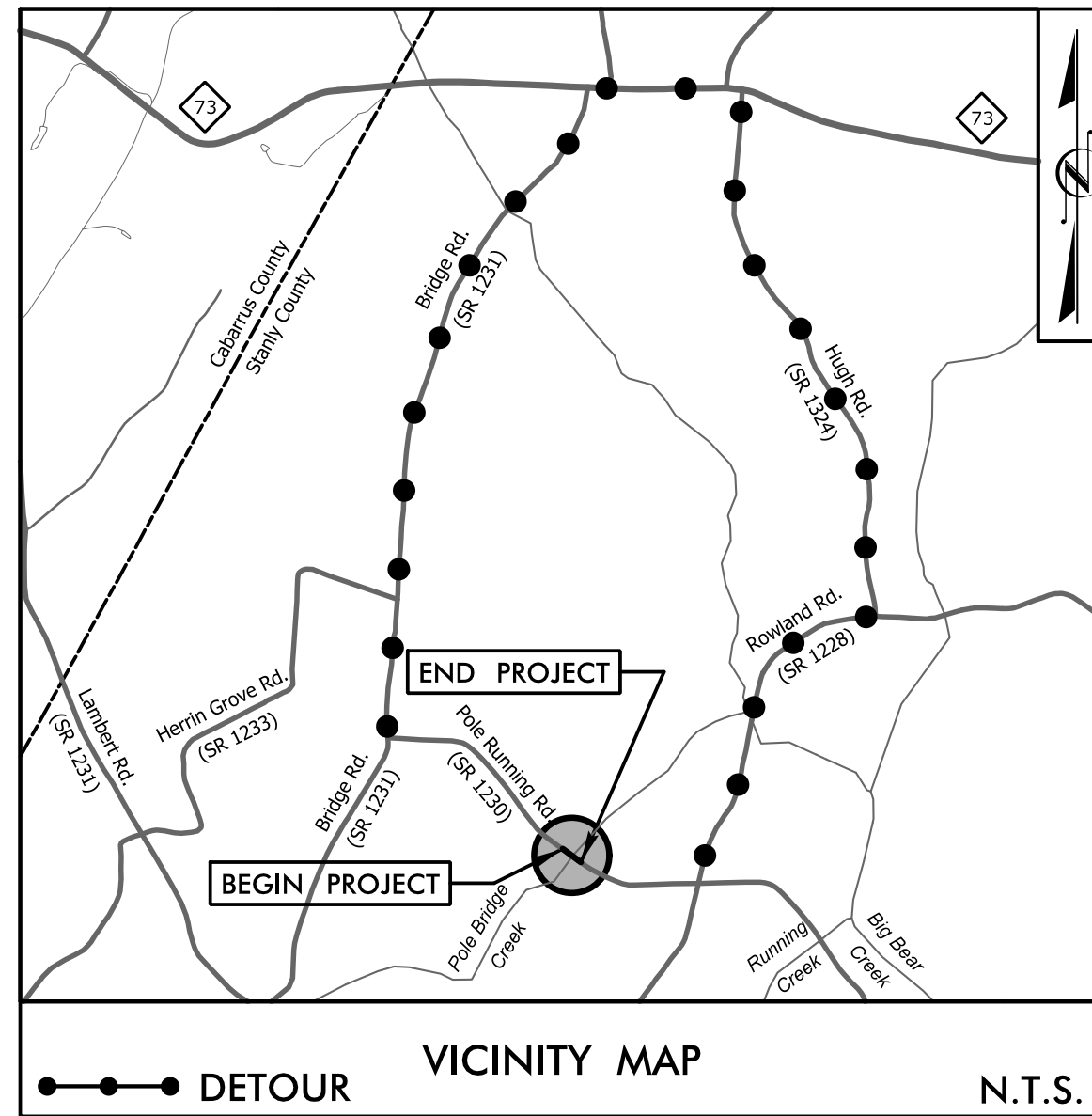

**FINAL PLANS**

STATE OF NORTH CAROLINA  
DIVISION OF HIGHWAYS

**STANLY COUNTY**

**LOCATION: BRIDGE #170 OVER POLE BRIDGE CREEK  
ON SR 1230 (POLE RUNNING RD.)**

**TYPE OF WORK: GRADING, PAVING, DRAINAGE, & STRUCTURE**

STATE	STATE PROJECT REFERENCE NO.	SHEET NO.	TOTAL SHEETS
N.C.	<b>17BP.10.R.63</b>	<b>1</b>	
STATE PROJ. NO.	F.A. PROJ. NO.	DESCRIPTION	
17BP.10.R.63		P.E.	
17BP.10.R.63		R/W & UTILITIES	
17BP.10.R.63		CONSTRUCTION	

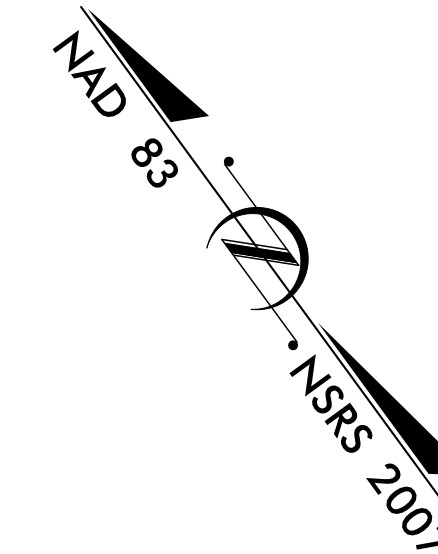
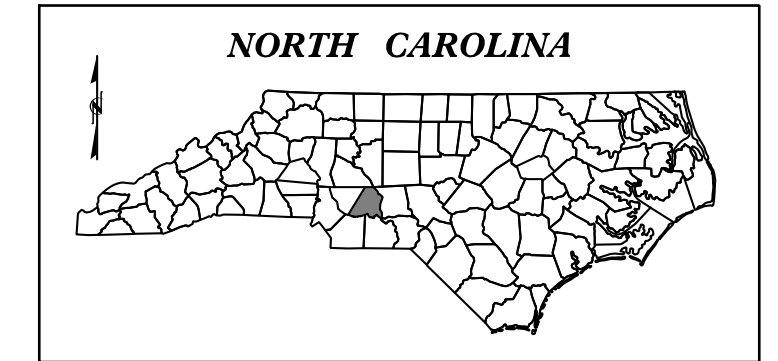

**BEGIN PROJECT WBS 17BP.10.R.63**  
-L- STA. 12 + 60.00

**END PROJECT WBS 17BP.10.R.63**  
-L- STA. 15 + 60.00

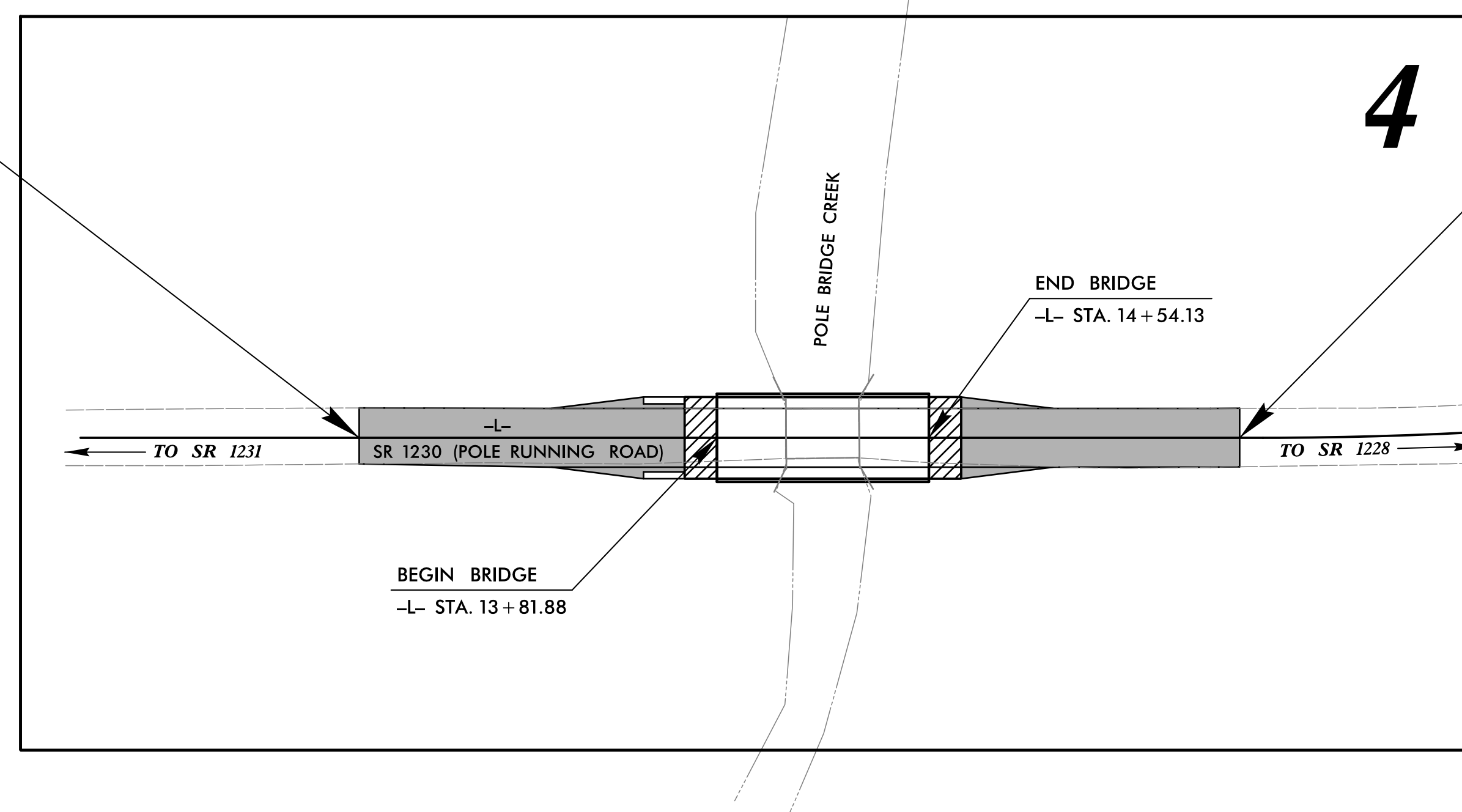

**CONTRACT:**

**CLEARING ON THIS PROJECT SHALL BE PERFORMED TO THE LIMITS ESTABLISHED BY METHOD II.**

**GRAPHIC SCALES**

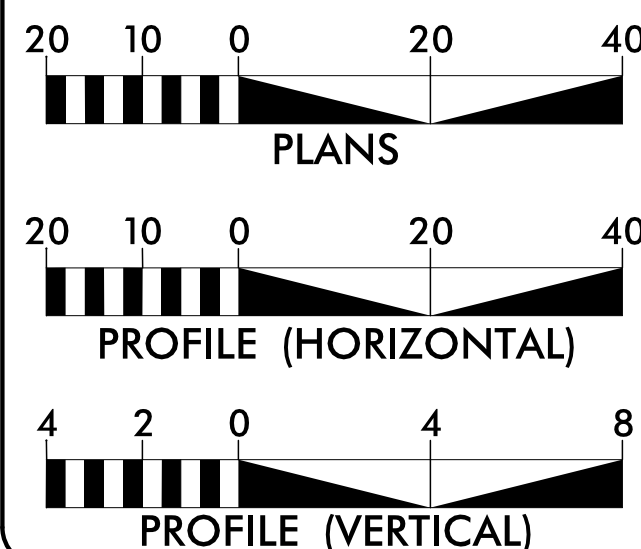

**DESIGN DATA**

ADT 2000 = 50  
ADT 2025 = 100  
DHV = N/A  
D = N/A  
T = N/A  
V = 55 MPH  
FUNC. CLASSIFICATION:  
LOCAL

**PROJECT LENGTH**

LENGTH OF ROADWAY PROJECT WBS 17BP.10.R.63 = 0.043 MILES  
LENGTH OF STRUCTURE PROJECT WBS 17BP.10.R.63 = 0.014 MILES  
TOTAL LENGTH OF PROJECT WBS 17BP.10.R.63 = 0.057 MILES

NCDOT CONTACT: GARLAND HAYWOOD, PE  
Division Bridge Manager

**PLANS PREPARED FOR THE NCDOT BY:**



**2012 STANDARD SPECIFICATIONS**

**RIGHT OF WAY DATE:**  
JULY 15, 2014

**LETTING DATE:**  
OCTOBER 7, 2015

**NIKKI T. HONEYCUTT, PE**  
PROJECT ENGINEER

**MAAMOON K. ABDELAZIZ**  
PROJECT DESIGNER

**HYDRAULICS ENGINEER**

DocuSigned by:  
**Edward J. Vance**  
SIGNATURE: [Signature]  
8/27/2015

DocuSigned by:  
**Nikki T. Honeycutt**  
SIGNATURE: [Signature]  
8/27/2015

**ROADWAY DESIGN ENGINEER**

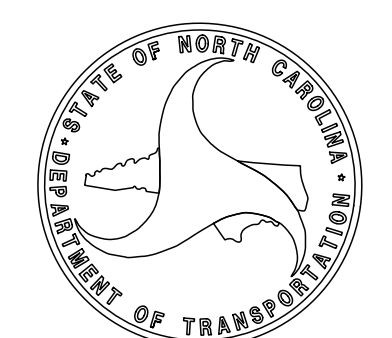

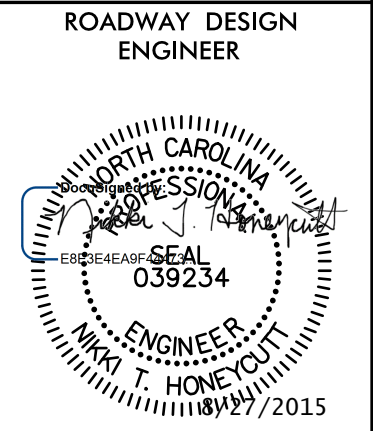

**INDEX OF SHEETS**

SHEET NUMBER	SHEET
1	TITLE SHEET
1-A	INDEX OF SHEETS, GENERAL NOTES, AND LIST OF STANDARD DRAWINGS
1-B	CONVENTIONAL SYMBOLS
3	SUMMARIES AND TYPICAL SECTION SHEET
4	PLAN AND PROFILE SHEET
TMP-1	TRAFFIC MANAGEMENT PLANS
EC-1 THRU RF-1	EROSION CONTROL PLANS
UO-1 THRU UO-2	UTILITIES BY OTHERS PLANS
X-1 THRU X-3	CROSS-SECTIONS

**GENERAL NOTES**

GENERAL NOTES: 2012 SPECIFICATIONS  
EFFECTIVE: 01-01-2012

GRADE LINE:  
GRADING AND SURFACING:

THE GRADE LINES SHOWN DENOTE THE FINISHED ELEVATION OF THE PROPOSED SURFACING AT GRADE POINTS SHOWN ON THE TYPICAL SECTIONS. GRADE LINES MAY BE ADJUSTED AT THEIR BEGINNING AND ENDING AND AT STRUCTURES AS DIRECTED BY THE ENGINEER IN ORDER TO SECURE A PROPER TIE-IN.

CLEARING:

CLEARING ON THIS PROJECT SHALL BE PERFORMED TO THE LIMITS ESTABLISHED BY METHOD II.

SUPERELEVATION:

ALL CURVES ON THIS PROJECT SHALL BE SUPERELEVATED IN ACCORDANCE WITH STD. NO. 225.04 USING THE RATE OF SUPERELEVATION AND RUNOFF SHOWN ON THE PLANS. SUPERELEVATION IS TO BE REVOLVED ABOUT THE GRADE POINTS SHOWN ON THE TYPICAL SECTIONS.

SHOULDER CONSTRUCTION:

ASPHALT, EARTH, AND CONCRETE SHOULDER CONSTRUCTION ON THE HIGH SIDE OF SUPERELEVATED CURVES SHALL BE IN ACCORDANCE WITH STD. NO. 560.01.

GUARDRAIL:

THE GUARDRAIL LOCATIONS SHOWN ON THE PLANS MAY BE ADJUSTED DURING CONSTRUCTION AS DIRECTED BY THE ENGINEER. THE CONTRACTOR SHOULD CONSULT WITH THE ENGINEER PRIOR TO ORDERING GUARDRAIL MATERIAL.

END BENTS:

THE ENGINEER SHALL CHECK THE STRUCTURE END BENT PLANS, DETAILS, AND CROSS-SECTION PRIOR TO SETTING OF THE SLOPE STAKES FOR THE EMBANKMENT OR EXCAVATION APPROACHING A BRIDGE.

RIGHT-OF-WAY MARKERS:

ALL RIGHT-OF-WAY MARKERS ON THIS PROJECT SHALL BE PLACED BY CONTRACT.

**STANDARD DRAWINGS**

2012 ROADWAY ENGLISH STANDARD DRAWINGS EFF. January, 2012

The following Roadway Standards as appear in "Roadway Standard Drawings" Highway Design Branch - N. C. Department of Transportation - Raleigh, N. C., Dated January, 2012 are applicable to this project and by reference hereby are considered a part of these plans:

STD.NO.	TITLE
DIVISION 2 - EARTHWORK	
200.02	Method of Clearing - Method II
225.02	Guide for Grading Subgrade - Secondary and Local
225.04	Method of Obtaining Superlevation - Two Lane Pavement
DIVISION 5 - SUBGRADE, BASES AND SHOULDERS	
560.01	Method of Shoulder Construction - High Side of Superelevated Curve - Method I
DIVISION 8 - INCIDENTALS	
840.29	Frames and Narrow Slot Flat Grates
840.35	Traffic Bearing Grated Drop Inlet
846.01	Concrete Curb, Gutter and Curb & Gutter
862.01	Guardrail Placement
862.02	Guardrail Installation
876.02	Guide for Rip Rap at Pipe Outlets
DIVISION 11 - WORK ZONE TRAFFIC CONTROL	
1110.01	Stationary Work Zone Signs - Mounting Height & Lateral Clearance
1145.01	Barricades - Type III
DIVISION 16 - EROSION CONTROL AND ROADSIDE DEVELOPMENT	
1605.01	Temporary Silt Fence
1607.01	Gravel Construction Entrance
1630.04	Stilling Basin For Pumped Effluent
1630.06	Special Stilling Basin
1631.01	Matting Installation
1632.03	Rock Inlet Sediment Trap Type C
1633.01	Temporary Rock Silt Check Type A

**Note: Not to Scale**





\*S.U.E. = *Subsurface Utility Engineering*

STATE OF NORTH CAROLINA  
DIVISION OF HIGHWAYS







PROJECT REFERENCE NO.	SHEET NO.
17BP10.R.63	1-B

# CONVENTIONAL PLAN SHEET SYMBOLS





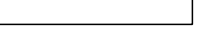
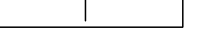
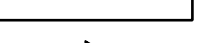
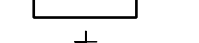
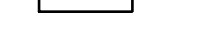

## BOUNDARIES AND PROPERTY:

State Line	-----
County Line	-----
Township Line	-----
City Line	-----
Reservation Line	-----
Property Line	-----
Existing Iron Pin	----- 
Property Corner	----- x
Property Monument	----- 
Parcel/Sequence Number	----- (123)
Existing Fence Line	----- x-x-x
Proposed Woven Wire Fence	----- o
Proposed Chain Link Fence	----- □
Proposed Barbed Wire Fence	----- ◇
Existing Wetland Boundary	----- WLB
Proposed Wetland Boundary	----- WLB
Existing Endangered Animal Boundary	----- EAB
Existing Endangered Plant Boundary	----- EPB
Known Soil Contamination: Boundary or Site	----- 
Potential Soil Contamination: Boundary or Site	----- 

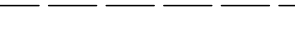

## BUILDINGS AND OTHER CULTURE:

Gas Pump Vent or U/G Tank Cap	----- 
Sign	----- 
Well	----- 
Small Mine	----- 
Foundation	----- 
Area Outline	----- 
Cemetery	----- 
Building	----- 
School	----- 
Church	----- 
Dam	----- 







## HYDROLOGY:

Stream or Body of Water	-----
Hydro, Pool or Reservoir	----- 
Jurisdictional Stream	----- JS
Buffer Zone 1	----- BZ 1
Buffer Zone 2	----- BZ 2
Flow Arrow	----- 
Disappearing Stream	----- 
Spring	----- 
Wetland	----- 
Proposed Lateral, Tail, Head Ditch	----- 
False Sump	----- 

## RAILROADS:

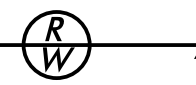
Standard Gauge	----- 
RR Signal Milepost	----- 
Switch	----- 
RR Abandoned	-----
RR Dismantled	-----











## RIGHT OF WAY:

Baseline Control Point	----- 
Existing Right of Way Marker	----- 
Existing Right of Way Line	-----
Proposed Right of Way Line	----- 
Proposed Right of Way Line with Iron Pin and Cap Marker	----- 
Proposed Right of Way Line with Concrete or Granite Marker	----- 
Existing Control of Access	----- 
Proposed Control of Access	----- 
Existing Easement Line	----- E
Proposed Temporary Construction Easement	----- E
Proposed Temporary Drainage Easement	----- TDE
Proposed Permanent Drainage Easement	----- PDE
Proposed Permanent Drainage / Utility Easement	----- DUE
Proposed Permanent Utility Easement	----- PUE
Proposed Temporary Utility Easement	----- TUE
Proposed Aerial Utility Easement	----- AUE





## ROADS AND RELATED FEATURES:

Proposed Permanent Easement with Iron Pin and Cap Marker	----- 
----------------------------------------------------------	---------------------------------------------------------------------------------------------

## ROADS AND RELATED FEATURES:

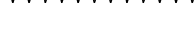

Existing Edge of Pavement	-----
Existing Curb	-----
Proposed Slope Stakes Cut	----- 
Proposed Slope Stakes Fill	----- 
Proposed Curb Ramp	----- 
Curb Cut Future Ramp	----- 
Existing Metal Guardrail	----- 
Proposed Guardrail	----- 
Existing Cable Guiderail	----- 
Proposed Cable Guiderail	----- 
Equality Symbol	----- 
Pavement Removal	----- 

## VEGETATION:

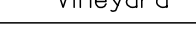



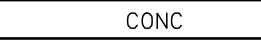
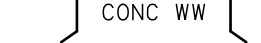
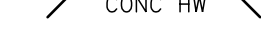
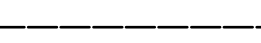



Single Tree	----- 
Single Shrub	----- 
Hedge	----- 
Woods Line	----- 

Orchard	----- 
Vineyard	----- 







## EXISTING STRUCTURES:

MAJOR:	
Bridge, Tunnel or Box Culvert	----- 
Bridge Wing Wall, Head Wall and End Wall	----- 
MINOR:	
Head and End Wall	----- 
Pipe Culvert	-----
Footbridge	----- 
Drainage Box: Catch Basin, DI or JB	----- 
Paved Ditch Gutter	-----
Storm Sewer Manhole	----- 
Storm Sewer	----- S





## UTILITIES:

POWER:	
Existing Power Pole	----- 
Proposed Power Pole	----- 
Existing Joint Use Pole	----- 
Proposed Joint Use Pole	----- 
Power Manhole	----- 
Power Line Tower	----- 
Power Transformer	----- 
U/G Power Cable Hand Hole	----- 
H-Frame Pole	----- 
Recorded U/G Power Line	----- P
Designated U/G Power Line (S.U.E.*)	----- P





## TELEPHONE:

Existing Telephone Pole	----- 
Proposed Telephone Pole	----- 
Telephone Manhole	----- 
Telephone Booth	----- 
Telephone Pedestal	----- 
Telephone Cell Tower	----- 
U/G Telephone Cable Hand Hole	----- 
Recorded U/G Telephone Cable	----- T
Designated U/G Telephone Cable (S.U.E.*)	----- T
Recorded U/G Telephone Conduit	----- TC
Designated U/G Telephone Conduit (S.U.E.*)	----- TC
Recorded U/G Fiber Optics Cable	----- T FO
Designated U/G Fiber Optics Cable (S.U.E.*)	----- T FO



## WATER:

Water Manhole	----- 
Water Meter	----- 
Water Valve	----- 
Water Hydrant	----- 
Recorded U/G Water Line	----- W
Designated U/G Water Line (S.U.E.*)	----- W
Above Ground Water Line	----- 



## TV:

TV Satellite Dish	----- 
TV Pedestal	----- 
TV Tower	----- 
U/G TV Cable Hand Hole	----- 
Recorded U/G TV Cable	----- TV
Designated U/G TV Cable (S.U.E.*)	----- TV
Recorded U/G Fiber Optic Cable	----- TV FO
Designated U/G Fiber Optic Cable (S.U.E.*)	----- TV FO











## GAS:

Gas Valve	----- 
Gas Meter	----- 
Recorded U/G Gas Line	----- G
Designated U/G Gas Line (S.U.E.*)	----- G
Above Ground Gas Line	----- 

## SANITARY SEWER:

Sanitary Sewer Manhole	----- 
Sanitary Sewer Cleanout	----- 
U/G Sanitary Sewer Line	----- SS
Above Ground Sanitary Sewer	----- 
Recorded SS Forced Main Line	----- FSS
Designated SS Forced Main Line (S.U.E.*)	----- FSS

## MISCELLANEOUS:

Utility Pole	----- 
Utility Pole with Base	----- 
Utility Located Object	----- 
Utility Traffic Signal Box	----- 
Utility Unknown U/G Line	----- 
U/G Tank; Water, Gas, Oil	----- 
Underground Storage Tank, Approx. Loc.	----- 
A/G Tank; Water, Gas, Oil	----- 
Geoenvironmental Boring	----- 
U/G Test Hole (S.U.E.*)	----- 
Abandoned According to Utility Records	----- AATUR
End of Information	----- E.O.I.



# DIVISION OF HIGHWAYS STATE OF NORTH CAROLINA

## EARTHWORK SUMMARY (IN CUBIC YARDS)

CHAIN	FROM STATION	TO STATION	SIDE	UNCL. EXCAVATION	UNDERCUT	EMBT + %	BORROW	WASTE
-L-	12 + 60.00	13 + 81.88	LT & RT	33		96	63	
-L-	14 + 54.13	15 + 60.00	LT & RT	65		36		29
LOSS DUE TO CLEARING AND GRUBBING				-160			160	
WASTE IN LIEU OF BORROW							-29	
<b>PROJECT TOTAL</b>				<b>0</b>		<b>132</b>	<b>194</b>	
ESTIMATE 5% FOR TOPSOIL ON BORROW PITS							10	
<b>GRAND TOTAL</b>						<b>132</b>	<b>204</b>	
SAY							210	

NOTE: Earthwork quantities are calculated by the Roadway Design Unit. These earthwork quantities are based in part on subsurface data provided by the Geotechnical Engineering Unit. Approximate quantities only. Unclassified Excavation, Borrow Excavation, Fine Grading, Clearing and Grubbing, Breaking of Existing Pavement, and Removal of Existing Pavement will be paid for at the contract lump sum price for "Grading."

PROJECT REFERENCE NO. 17BP10R.63	SHEET NO. 3
<b>STV</b> STV Engineers, Inc. 900 West Trade St., Suite 715 Charlotte, NC 28202 NC License Number F-0991	ROADWAY DESIGN ENGINEER  PAVEMENT DESIGN ENGINEER
PAVEMENT DESIGN PROVIDED BY NCDOT	

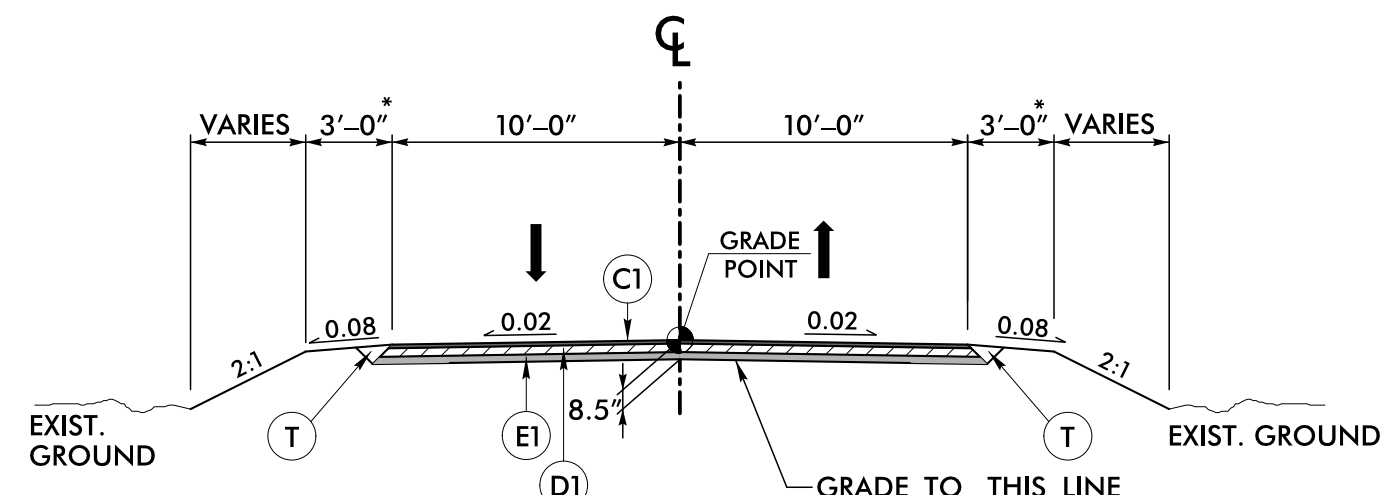

\* 7'-0" WITH GUARDRAIL  
 \*\* ALL PAVEMENT SLOPES ARE 1:1 UNLESS SHOWN OTHERWISE.

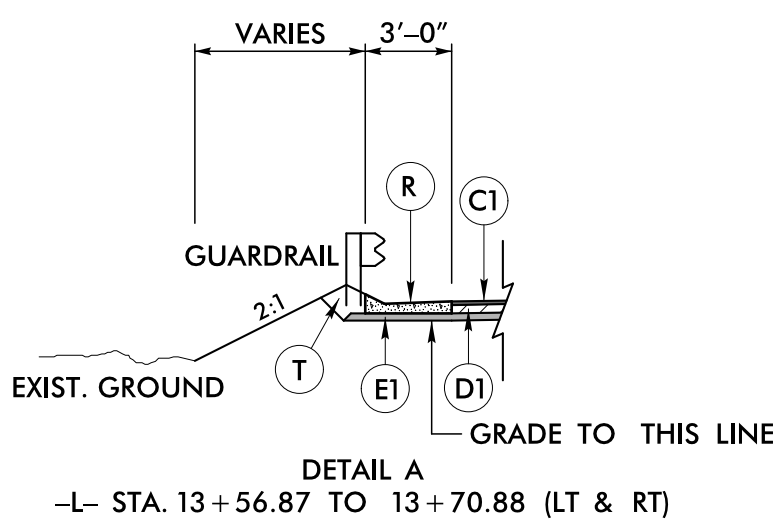

PAVEMENT SCHEDULE	
C1	PROP. APPROX. 1.5" ASPHALT CONCRETE SURFACE COURSE, TYPE S9.5B, AT AN AVERAGE RATE OF 168 LBS. PER SQ. YD.
D1	PROP. APPROX. 3.5" ASPHALT CONCRETE INTERMEDIATE COURSE, TYPE I19.0B, AT AN AVERAGE RATE OF 399 LBS. PER SQ. YD.
E1	PROP. APPROX. 3.5" ASPHALT CONCRETE BASE COURSE, TYPE B25.0B, AT AN AVERAGE RATE OF 399 LBS. PER SQ. YD.
R	CONCRETE SHOULDER BERM GUTTER
T	EARTH MATERIAL
U	EXISTING PAVEMENT

## LIST OF PIPES, ENDWALLS, ETC. (FOR PIPES 48" & UNDER)

STATION	SIZE	THICKNESS OR GAUGE	LOCATION (LT, RT, OR CI)	STRUCTURE NO.	TOP ELEVATION	INVERT ELEVATION	SLOPE CRITICAL	CLASS III R.C. PIPE OR (UNLESS NOTED OTHERWISE)								BITUMINOUS COATED C.S. PIPE TYPE B (UNLESS NOTED OTHERWISE)								CLASS III R.C. PIPE OR ALUMINIZED C.S. PIPE, TYPE IR OR HDPE PIPE, TYPE S OR D								ENDWALLS	QUANTITIES FOR ORDERING OR STRUCTURES	TYPE OF GRATE	D.I. STD. 840.14 OR STD. 840.15	D.I. FRAME AND GRATE STD. 840.16	G.D.I. TYPE "A" STD. 840.17 OR 840.26	G.D.I. TYPE "B" STD. 840.18 OR 840.27	G.D.I. TYPE "D" STD. 840.19 OR 840.28	TRAFFIC BEARING G.D.I. STD. 840.35	G.D.I. FRAME WITH GRATE STD. 840.20	G.D.I. FRAME WITH TWO GRATES STD. 840.22	G.D.I. (N.S.) FRAME WITH GRATE STD. 840.29	G.D.I. (N.S.) FRAME WITH TWO GRATES STD. 840.24	J.B. STD. 840.31 OR 840.32	CORR. STEEL ELBOWS NO. & SIZE	CONC. COLLARS CL. "B" C.Y. STD. 840.72	CONC. & BRICK PIPE PLUG, C.Y. STD. 840.71	PIPE REMOVAL LIN. FT.	ABBREVIATIONS		REMARKS																			
								12"	15"	18"	24"	30"	36"	42"	48"	12"	15"	18"	24"	30"	36"	42"	48"	12"	15"	18"	24"	30"	36"	42"	48"																			C.U. YDS.	R.C.P.		C.S.P.	E	F	G	C.B.	N.D.I.	D.I.	G.D.I.	G.D.I. (N.S.)	J.B.	M.H.	T.B.D.I.	T.B.J.B.						
-L- STA. 13+62	LT	1	OUT		505.16'	499.00'	497.74'	6.00	21																																																														
-L- STA. 13+62	RT	2	OUT		505.16'	498.20'	497.00'	6.00	22																																																														
<b>TOTAL</b>									43'																																																														

\* W = MEASURED FROM "N" AT THE BEGINNING OF THE ANCHOR TO "N" AT THE END OF THE ANCHOR.  
 "N" = DISTANCE FROM EDGE OF LANE TO FACE OF GUARDRAIL.  
 TOTAL SHOULDER WIDTH = DISTANCE FROM EDGE OF TRAVEL LANE TO SHOULDER BREAK POINT.  
 FLARE LENGTH = DISTANCE FROM LAST SECTION OF PARALLEL GUARDRAIL TO END OF GUARDRAIL.  
 W = TOTAL WIDTH OF FLARE FROM BEGINNING OF TAPER TO END OF GUARDRAIL.  
 G = GATING IMPACT ATTENUATOR TYPE 350  
 NG = NON-GATING IMPACT ATTENUATOR TYPE 350

## GUARDRAIL SUMMARY

SURVEY LINE	BEG. STA.	END STA.	LOCATION	LENGTH			WARRANT POINT		"N" DIST. FROM E.O.L.	TOTAL SHOUL. WIDTH	FLARE LENGTH		W*	ANCHORS							IMPACT ATTENUATOR TYPE 350	SINGLE FACED GUARDRAIL	REMOVE EXISTING GUARDRAIL	REMOVE AND STOCKPILE EXISTING GUARDRAIL	REMARKS					
				STRAIGHT	SHOP CURVED	DOUBLE FACED	APPROACH END	TRAILING END			APPROACH END	TRAILING END		APPROACH END	TRAILING END	APPROACH END	TRAILING END	XI MOD	B-77	GRAU 350						M-350	TYPE III	CAT-1	VI MOD	BIC
-L-	13 + 00.63	13 + 81.88	LT	81.25					7																					
-L-	13 + 00.63	13 + 81.88	RT	81.25				13 + 81.88	7		50																			
-L-	14 + 54.13	15 + 35.37	LT	81.25				14 + 54.13	7		50																			
-L-	14 + 54.13	15 + 35.37	RT	81.25				14 + 54.13	7		50																			
<b>TOTAL:</b>				325																										
TOTAL ANCHOR LENGTH:				275																										
TOTAL GUARDRAIL LENGTH:				50																										
SAY:				50																										

8/27/2015  
 F:\Roadway\proj\shh\10R63\_rdy\_psh03.dgn  
 ClevesP



### DATUM DESCRIPTION

THE LOCALIZED COORDINATE SYSTEM DEVELOPED FOR THIS PROJECT IS BASED ON THE STATE PLANE COORDINATES ESTABLISHED BY NCDOT FOR MONUMENT "BL-3" WITH NAD 83/NSRS 2007 STATE PLANE GRID COORDINATES OF NORTHING: 587595.246(FT) EASTING: 1593071.667(FT) ELEVATION: 504.30(FT)

THE AVERAGE COMBINED GRID FACTOR USED ON THIS PROJECT (GROUND TO GRID) IS: 0.999853

THE N.C. LAMBERT GRID BEARING AND LOCALIZED HORIZONTAL GROUND DISTANCE FROM "BL-3" TO L- STATION 12+60.00 IS N 60°20' 32.300" W 114.159(FT)

ALL LINEAR DIMENSIONS ARE LOCALIZED HORIZONTAL DISTANCES VERTICAL DATUM USED IS NAVD 88

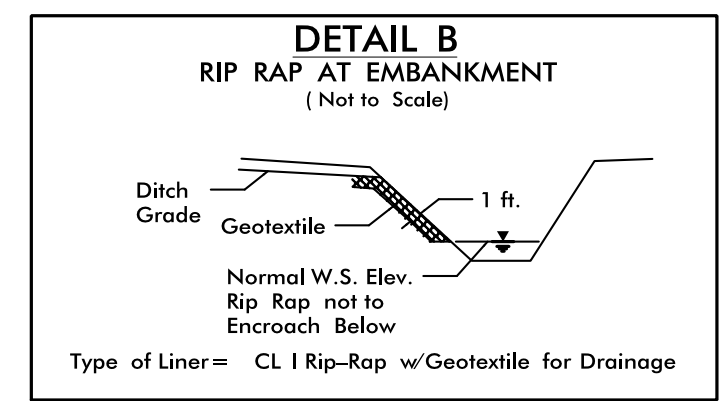
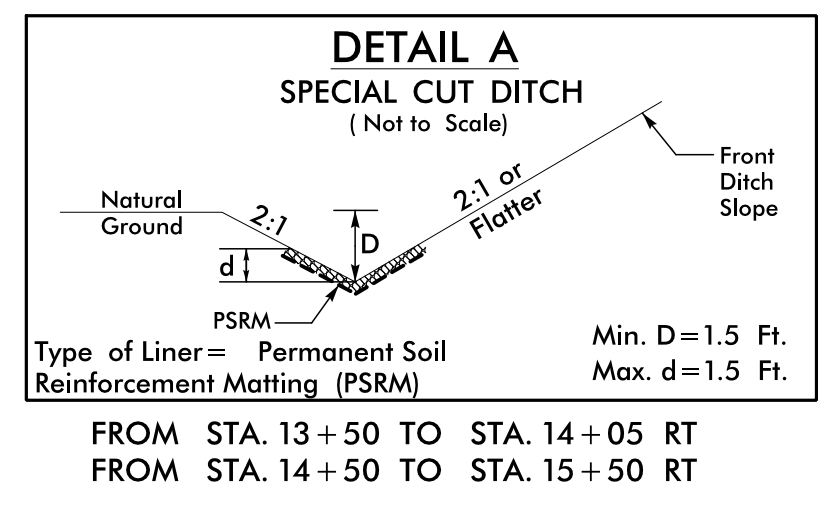

PROJECT REFERENCE NO. 17BP10.R.63	SHEET NO. 4
RW SHEET NO.	
<b>STV Engineers, Inc.</b> 800 West Trade St., Suite 715 Charlotte, NC 28202 NC License Number F-0991	
ROADWAY DESIGN ENGINEER 	HYDRAULICS ENGINEER 

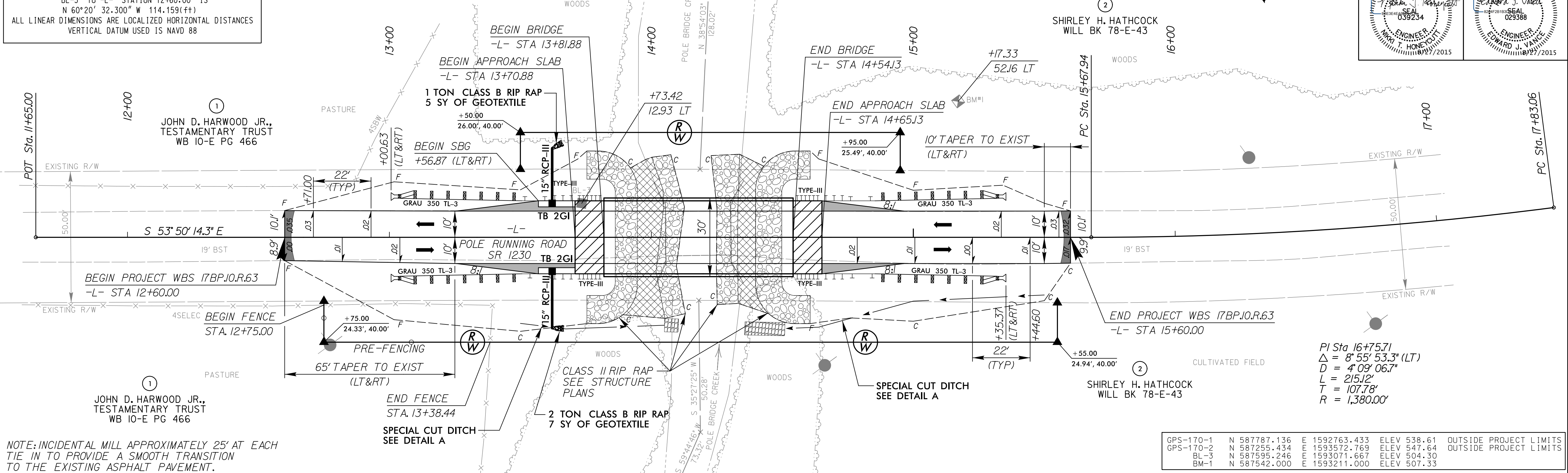

NOTE: INCIDENTAL MILL APPROXIMATELY 25' AT EACH TIE IN TO PROVIDE A SMOOTH TRANSITION TO THE EXISTING ASPHALT PAVEMENT.

GPS-170-1	N 587787.136	E 1592763.433	ELEV 538.61	OUTSIDE PROJECT LIMITS
GPS-170-2	N 587255.434	E 1593572.769	ELEV 547.64	OUTSIDE PROJECT LIMITS
BL-3	N 587595.246	E 1593071.667	ELEV 504.30	
BM-1	N 587542.000	E 1593211.000	ELEV 507.33	

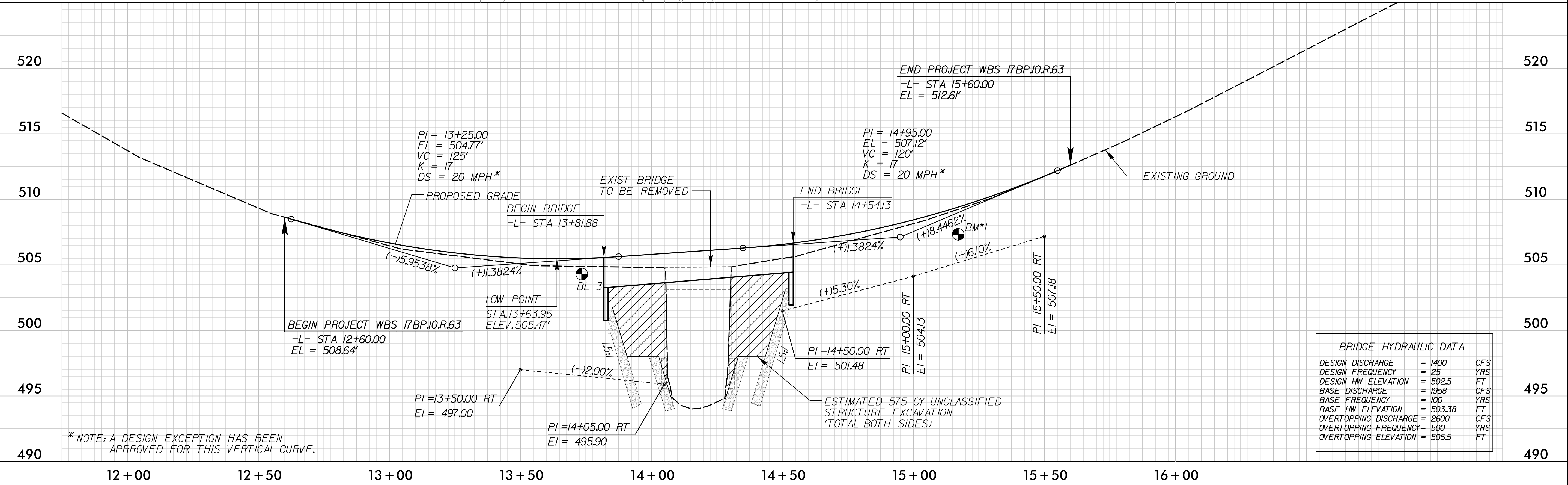

\* NOTE: A DESIGN EXCEPTION HAS BEEN APPROVED FOR THIS VERTICAL CURVE.

8/27/2015  
F:\r\ogdway\proj\10R63\_rdy\_psh04.dgn  
C:\esep



# OFF-SITE DETOUR SIGNING AND ROAD CLOSURE SIGNING

PROJECT REFERENCE NO. 17BPJ0R.63	SHEET NO. TMP-1
RW SHEET NO.	

**STV** 100 Years  
STV Engineers, Inc.  
800 West Trade St., Suite 715  
Charlotte, NC 28202  
NC License Number F-0991

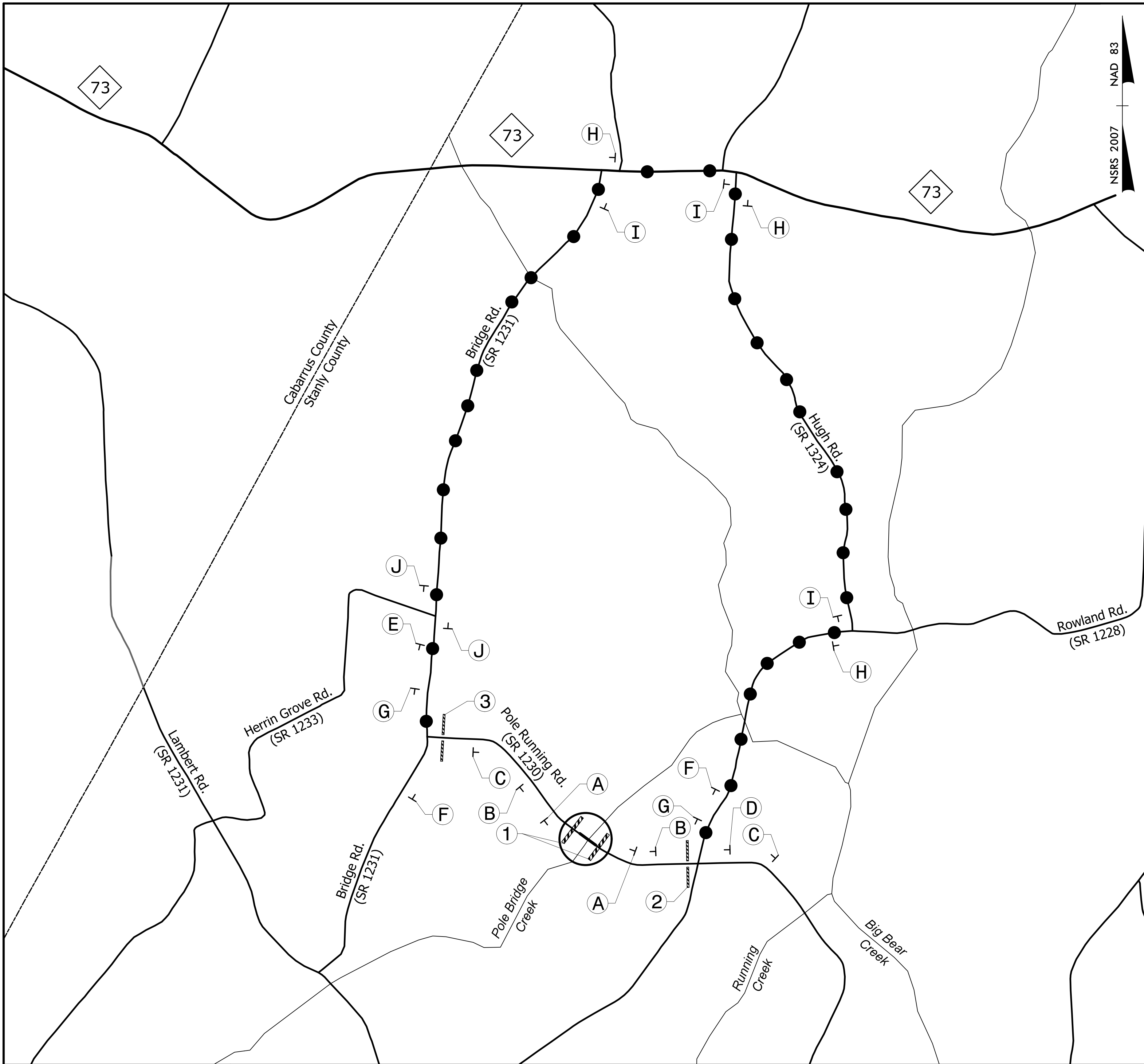
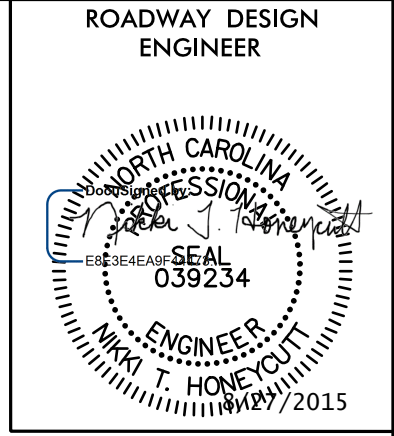

**1**

R11-2  
48" X 30"  
ROAD CLOSED

TYPE III BARRICADE (S)

**2**

R11-4  
60" X 30"  
ROAD CLOSED TO THRU TRAFFIC

M4-10R  
48" X 18"  
DETOUR

TYPE III BARRICADE

**3**

R11-3  
60" X 30"  
ROAD CLOSED 1 MILE AHEAD LOCAL TRAFFIC ONLY

M4-10L  
48" X 18"  
DETOUR

TYPE III BARRICADE

**A**

ROAD CLOSED 500 FT  
W20-3  
48" X 48"

**B**

ROAD CLOSED 1000 FT  
W20-3  
48" X 48"

**C**

ROAD CLOSED AHEAD  
W20-3  
48" X 48"

**D**

DETOUR AHEAD  
W20-2  
48" X 48"

**E**

ROAD CLOSED AHEAD  
W20-3  
48" X 48"

**F**

ROAD CLOSED AHEAD  
W20-3  
48" X 48"

**G**

END DETOUR  
M4-8 A  
24" X 18"

**H**

DETOUR  
M4-8  
24" X 12"

M6-1 L  
21" X 15"

**I**

DETOUR  
M4-8  
24" X 12"

M6-1  
21" X 15"

**J**

DETOUR  
M4-8  
24" X 12"

M6-3  
21" X 15"

SEE ROADWAY STD DWG 1101.03, SHEET 1 OF 9 FOR ADVANCE WARNING AND BARRICADE PLACEMENT.

Scale: 1" = 900'

8/21/2015  
F:\TrafficControl\TOP\10R63\_rdy\_tmp01.dgn  
ClavesP

**PROJECT WBS: 17BP.10.R.63**

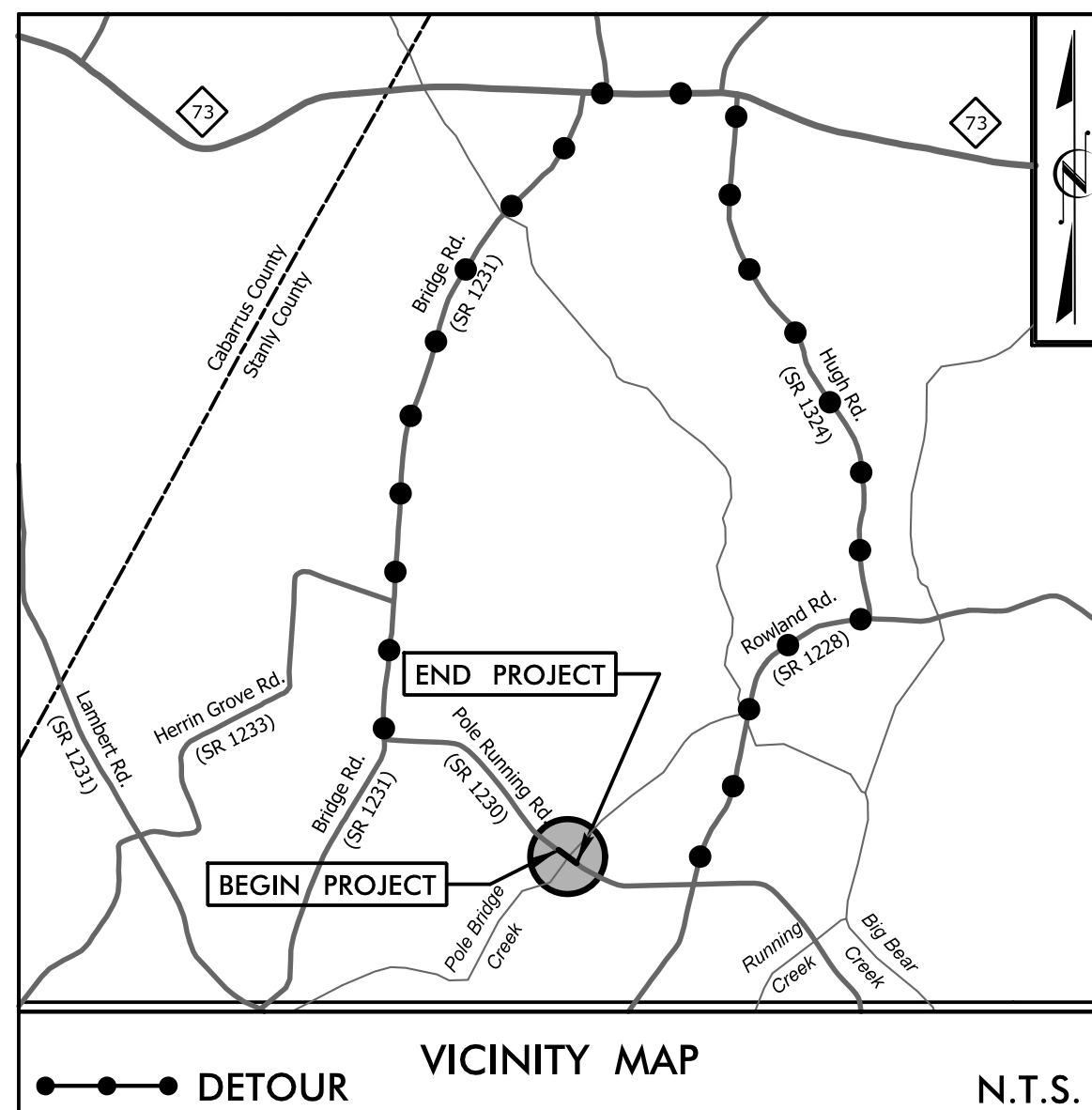

**EROSION CONTROL PLANS**

STATE OF NORTH CAROLINA  
DIVISION OF HIGHWAYS  
PLAN FOR PROPOSED  
HIGHWAY EROSION CONTROL  
**STANLY COUNTY**

**LOCATION: BRIDGE #890170 OVER POLE BRIDGE CREEK  
ON SR 1230 (POLE RUNNING RD.)**

**TYPE OF WORK: GRADING, PAVING, DRAINAGE, & STRUCTURE**

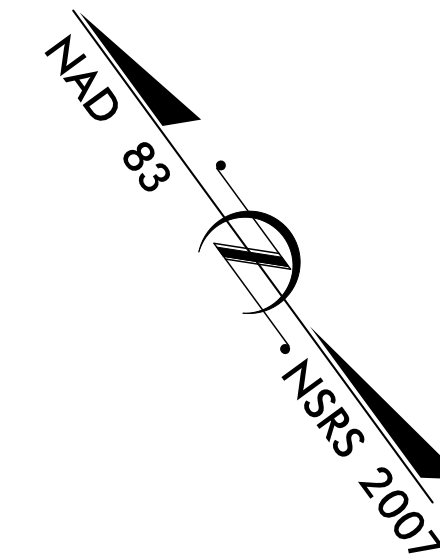

STATE	STATE PROJECT REFERENCE NO.	SHEET NO.	TOTAL SHEETS
N.C.	17BP.10.R.63	EC-1	7
STATE PROJ. NO.	F.A. PROJ. NO.	DESCRIPTION	
17BP.10.R.63		P.E.	
17BP.10.R.63		R/W & UTILITIES	
17BP.10.R.63		CONSTRUCTION	

**EROSION AND SEDIMENT CONTROL MEASURES**

Std. #	Description	Symbol
1630.03	Temporary Silt Ditch	TD
1630.05	Temporary Diversion	TD
1605.01	Temporary Silt Fence	TSF
1606.01	Special Sediment Control Fence	SSCF
1622.01	Temporary Berms and Slope Drains	TBSD
1630.02	Silt Basin Type B	SBS
1633.01	Temporary Rock Silt Check Type-A	TRSCA
	Temporary Rock Silt Check Type-A with Matting and Polyacrylamide (PAM)	TRSCA-PAM
1633.02	Temporary Rock Silt Check Type-B	TRSCB
	Wattle/Coir Fiber Wattle	WCFW
	Wattle/Coir Fiber Wattle with Polyacrylamide (PAM)	WCFW-PAM
1634.01	Temporary Rock Sediment Dam Type-A	TRSDA
1634.02	Temporary Rock Sediment Dam Type-B	TRSDB
1635.01	Rock Pipe Inlet Sediment Trap Type-A	RPISTRA
1635.02	Rock Pipe Inlet Sediment Trap Type-B	RPISTRB
1630.04	Stilling Basin	SB
1630.06	Special Stilling Basin	SSB
	Rock Inlet Sediment Trap:	
1632.01	Type A	A
1632.02	Type B	B
1632.03	Type C	C
	Skimmer Basin	SKB
	Tiered Skimmer Basin	TSKB
	Infiltration Basin	IB

**BEGIN PROJECT WBS 17BP.10.R.63**  
-L- STA. 12 + 60.00

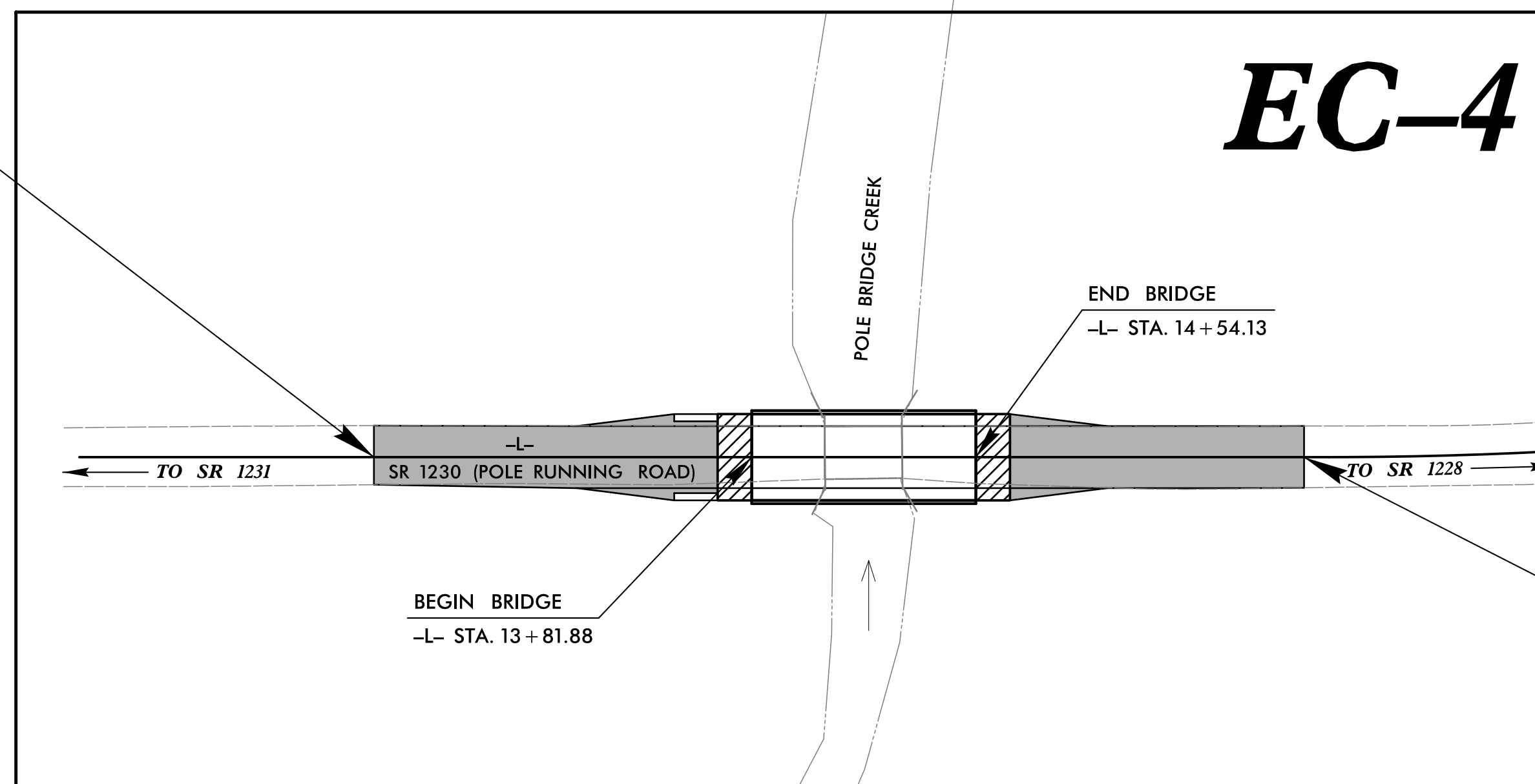

**THIS PROJECT CONTAINS  
EROSION CONTROL PLANS  
FOR CLEARING AND  
GRUBBING PHASE OF  
CONSTRUCTION.**

THIS PROJECT HAS  
BEEN DESIGNED TO  
SENSITIVE WATERSHED  
STANDARDS.

ENVIRONMENTALLY  
SENSITIVE AREA(S) EXIST  
ON THIS PROJECT

Refer To E. C. Special Provisions  
for Special Considerations.

CLEARING ON THIS PROJECT SHALL BE PERFORMED  
TO THE LIMITS ESTABLISHED BY METHOD II.

**GRAPHIC SCALE**

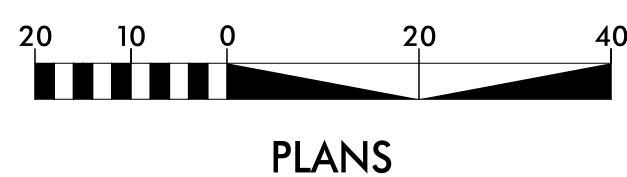

ROADSIDE ENVIRONMENTAL UNIT  
DIVISION OF HIGHWAYS  
STATE OF NORTH CAROLINA

Level III Designer #3645  
Ryan O'Mahony, PE

THESE EROSION AND SEDIMENT CONTROL PLANS COMPLY  
WITH THE REGULATIONS SET FORTH BY THE  
NCG-010000 GENERAL CONSTRUCTION PERMIT EFFECTIVE AUGUST 3, 2011  
ISSUED BY THE NORTH CAROLINA DEPARTMENT OF ENVIRONMENT AND  
NATURAL RESOURCES DIVISION OF WATER QUALITY.

PREPARED IN THE OFFICE OF:



**2012 STANDARD SPECIFICATIONS**

**Roadway Standard Drawings**

The following roadway english standards as appear in "Roadway Standard Drawings"- Roadway Design Unit - N. C. Department of Transportation - Raleigh, N. C., dated January 2012 and the latest revision thereto are applicable to this project and by reference hereby are considered a part of these plans.

- 1605.01 Temporary Silt Fence
- 1607.01 Gravel Construction Entrance
- 1630.04 Stilling Basin
- 1630.06 Special Stilling Basin
- 1631.01 Matting Installation
- 1632.03 Rock Inlet Sediment Trap Type C
- 1633.01 Temporary Rock Silt Check Type A

**EROSION CONTROL PLANS  
8/27/2015**

**CONTRACT:**

# SILT FENCE WATTLE BREAK DETAIL

PROJECT REFERENCE NO. 17BPJ0.R.63	SHEET NO. EC-2
RW SHEET NO.	
 STV Engineers, Inc. 800 West Trade St., Suite 715 Charlotte, NC 28202 NC License Number F-0991	

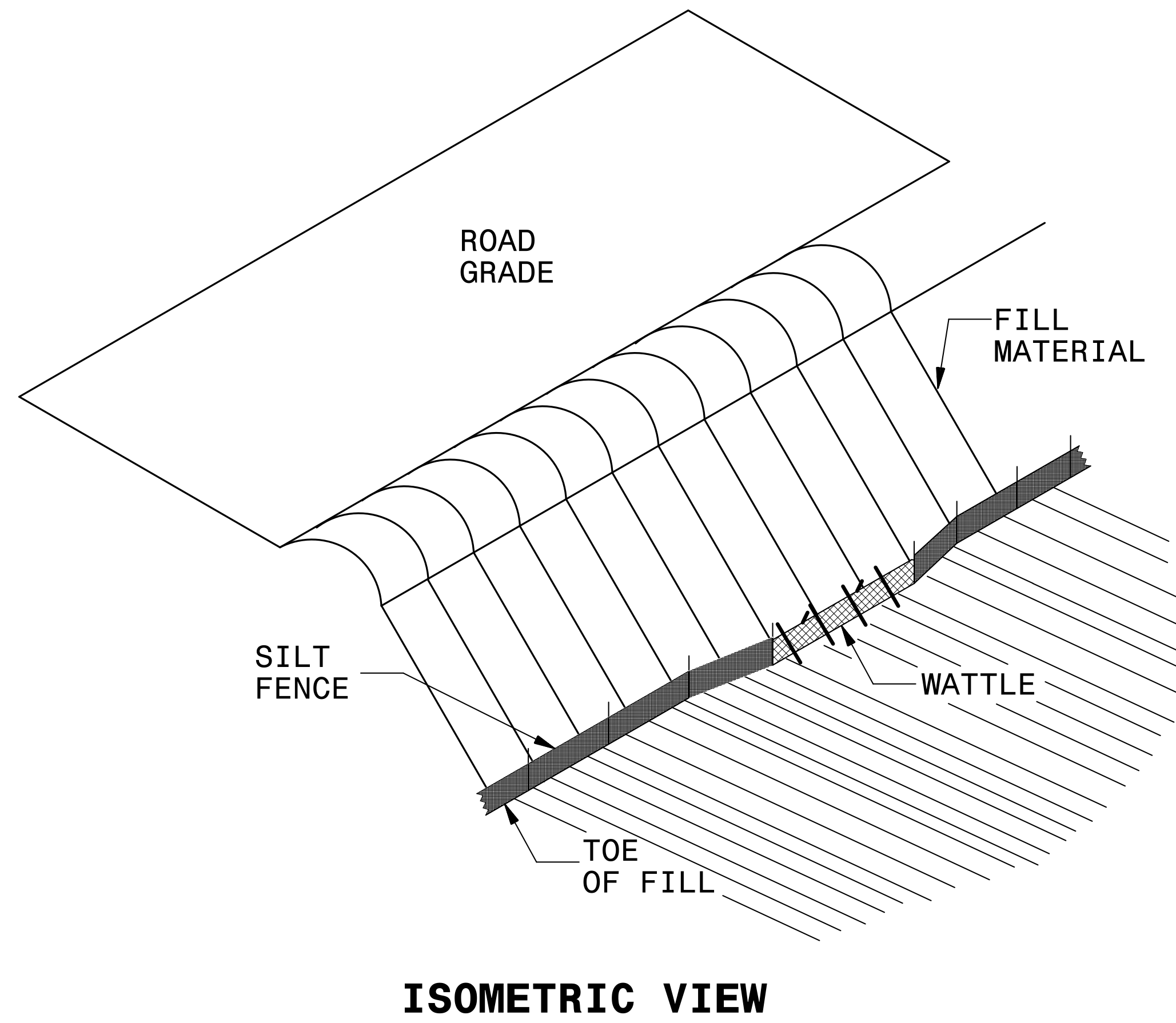

**NOTES:**

USE MINIMUM 12 IN. DIAMETER EXCELSIOR WATTLE AND LENGTH OF 10 FT.

EXCAVATE A 1 TO 2 INCH TRENCH FOR WATTLE TO BE PLACED.

DO NOT PLACE WATTLE ON TOE OF SLOPE.

USE 2 FT. WOODEN STAKES WITH A 2 IN. BY 2 IN. NOMINAL CROSS SECTION.

INSTALL A MINIMUM OF 2 UPSLOPE STAKES AND 4 DOWNSLOPE STAKES AT AN ANGLE TO WEDGE WATTLE TO GROUND.

PROVIDE STAPLES MADE OF 0.125 IN. DIAMETER STEEL WIRE FORMED INTO A U SHAPE NOT LESS THAN 12" IN LENGTH.

INSTALL STAPLES APPROXIMATELY EVERY 1 LINEAR FOOT ON BOTH SIDES OF WATTLE AND AT EACH END TO SECURE IT TO THE SOIL.

WATTLE INSTALLATION CAN BE ON OUTSIDE OF THE SILT FENCE AS DIRECTED.

INSTALL TEMPORARY SILT FENCE IN ACCORDANCE WITH SECTION 1605 OF THE STANDARD SPECIFICATIONS.

**INSET A**

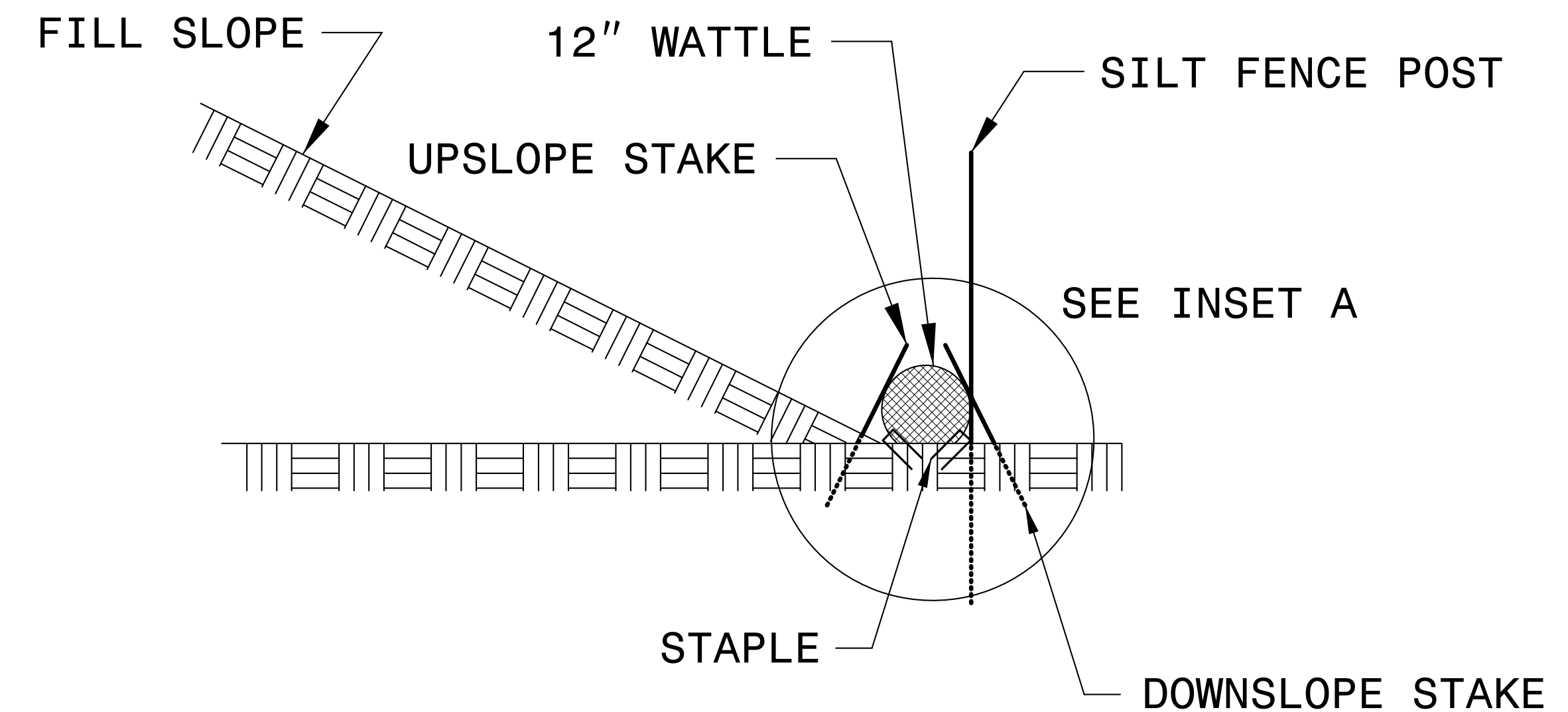
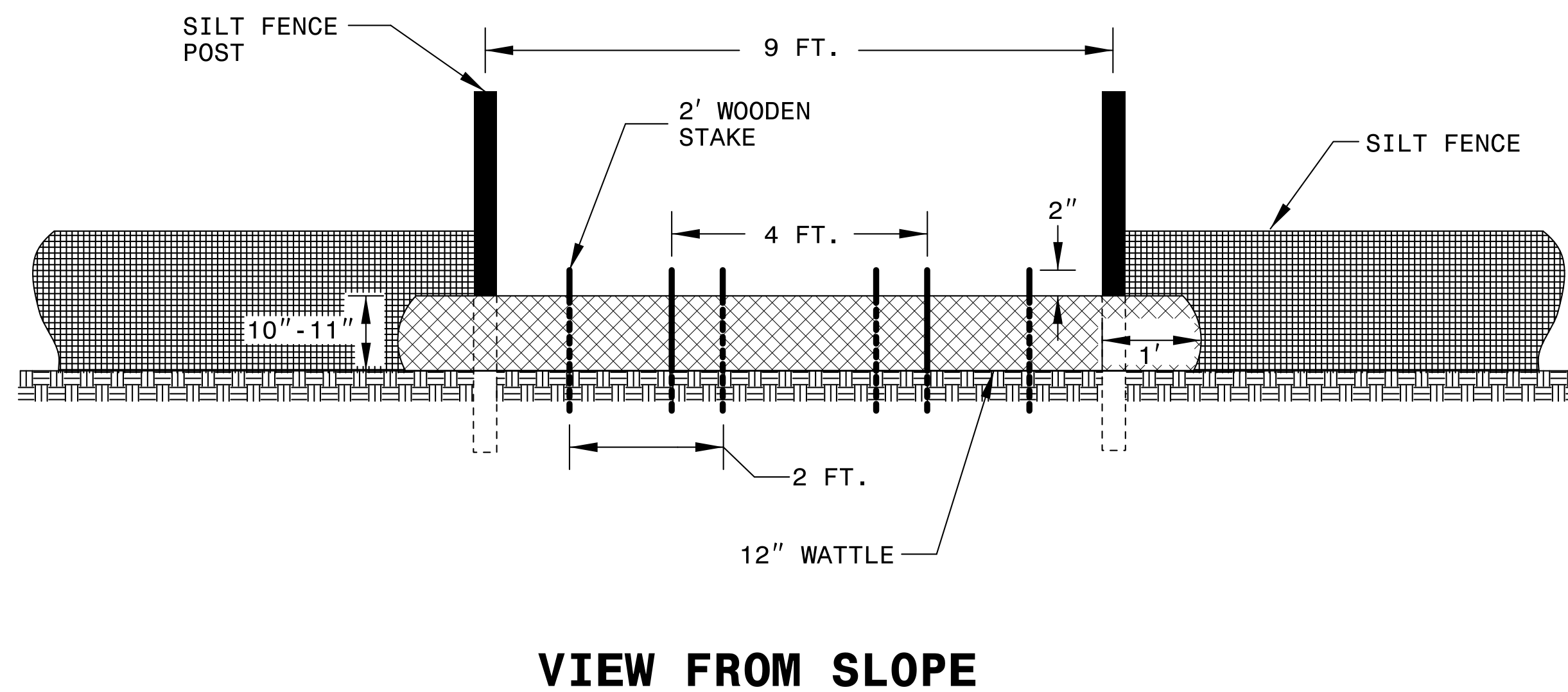
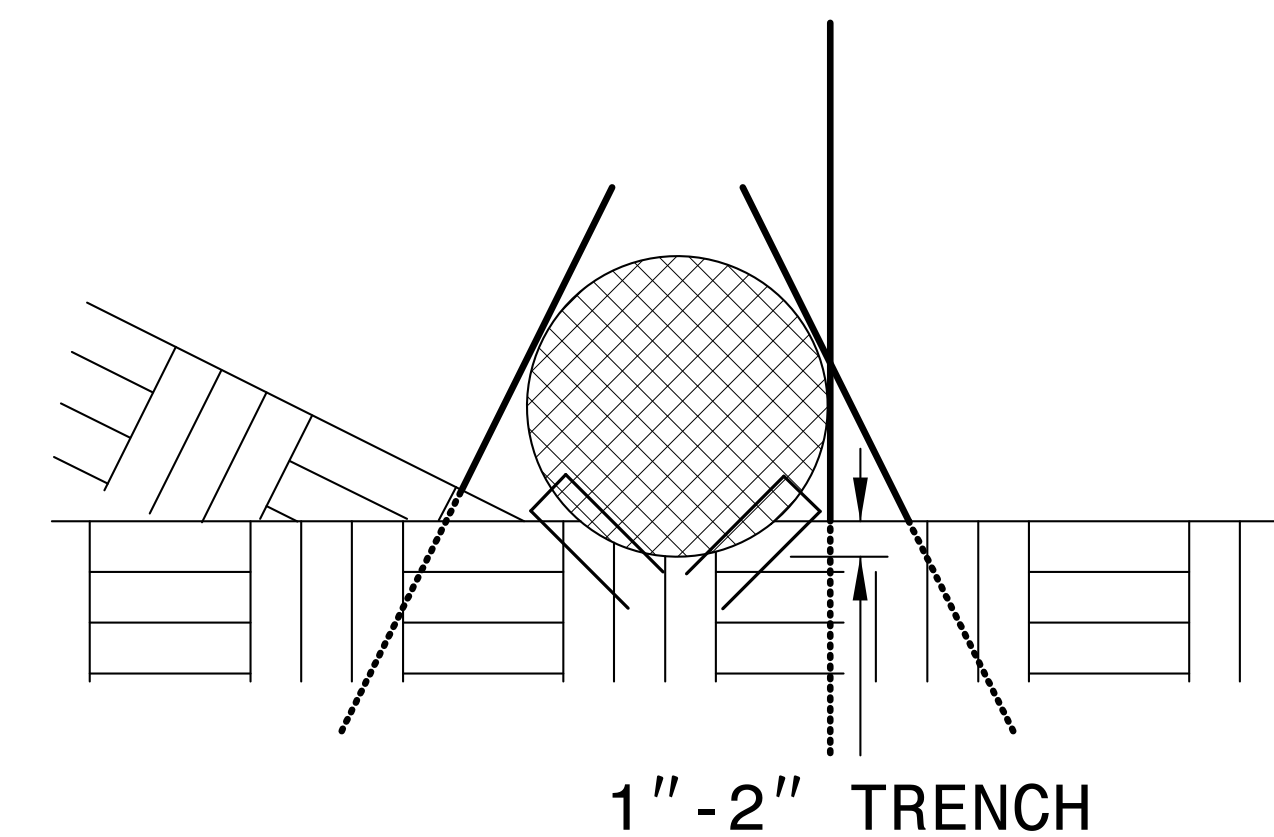



PROJECT REFERENCE NO. 17BP10.R.63	SHEET NO. EC-2A
RW SHEET NO.	
 STV Engineers, Inc. 800 West Trade St., Suite 715 Charlotte, NC 28202 NC License Number F-0991	

# TEMPORARY ROCK SILT CHECK TYPE 'A' WITH EXCELSIOR MATTING AND POLYACRYLAMIDE (PAM)

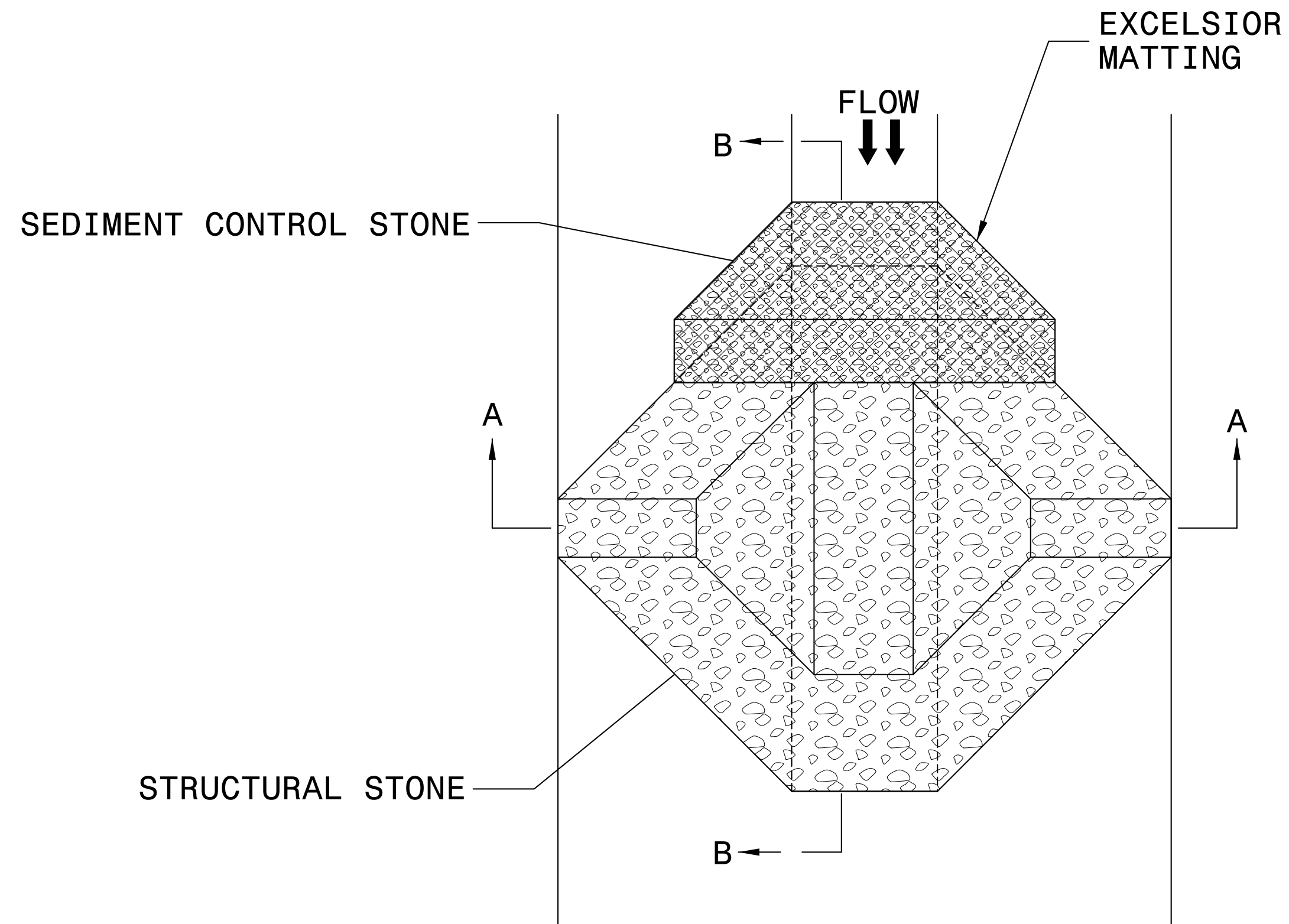

PLAN

## NOTES

INSTALL TEMPORARY ROCK SILT CHECK TYPE A IN ACCORDANCE WITH ROADWAY STANDARD DRAWING NO. 1633.01.

USE EXCELSIOR FOR MATTING MATERIAL AND ANCHOR MATTING SECTION AT TOP AND BOTTOM WITH CLASS B STONE.

PRIOR TO POLYACRYLAMIDE (PAM) APPLICATION, OBTAIN A SOIL SAMPLE FROM PROJECT LOCATION, AND FROM OFFSITE MATERIAL, AND ANALYZE FOR APPROPRIATE PAM FLOCCULANT TO BE APPLIED TO EACH ROCK SILT CHECK.

INITIALLY APPLY 4 OUNCES OF POLYACRYLAMIDE (PAM) TO TOP OF MATTING SECTION AND AFTER EVERY RAINFALL EVENT THAT EQUALS OR EXCEEDS 0.50 INCHES.

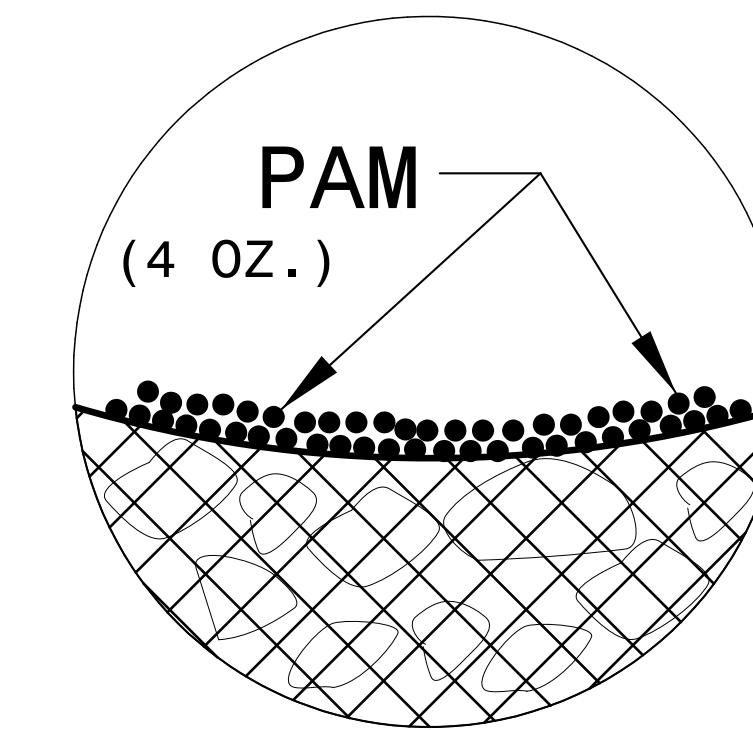

INSET A

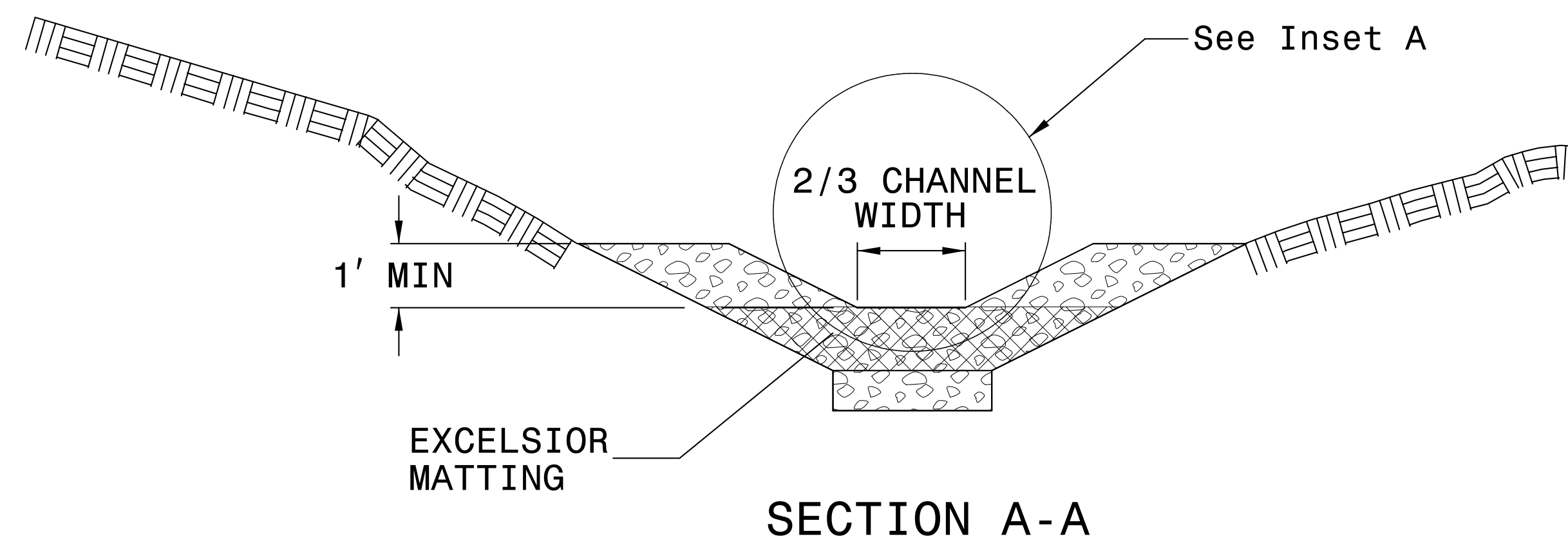

SECTION A-A

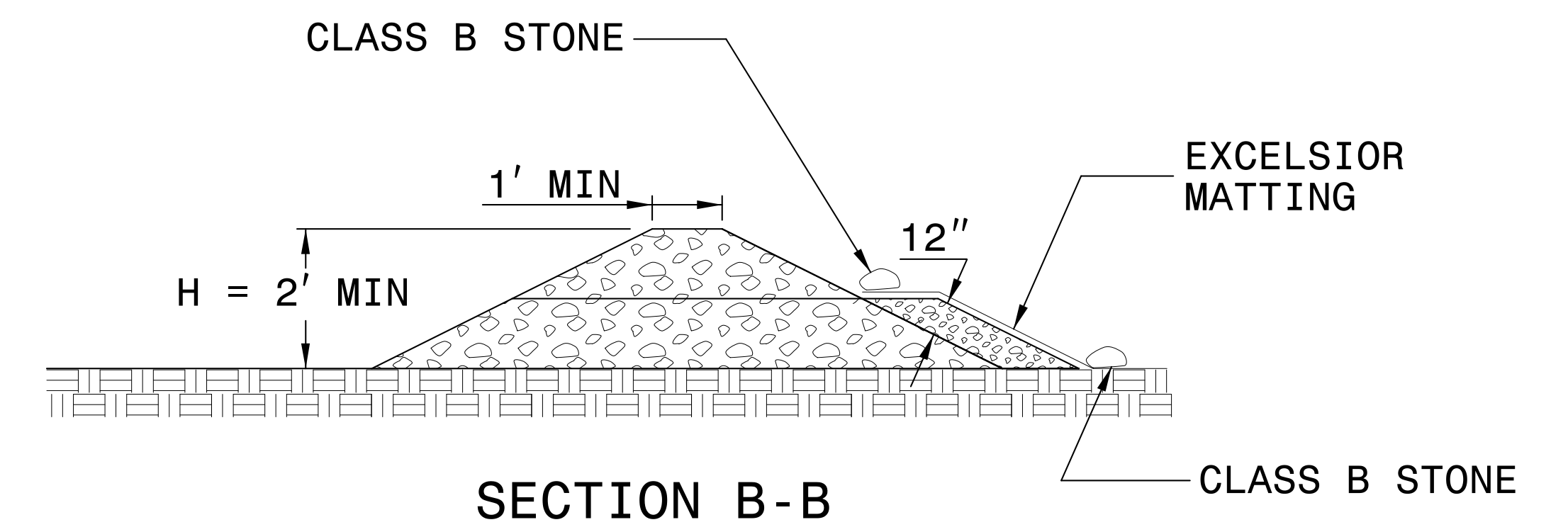

SECTION B-B

NOT TO SCALE

DIVISION OF HIGHWAYS  
STATE OF NORTH CAROLINA

PROJECT REFERENCE NO.	SHEET NO.
17BPJ0.R.63	EC-3
RW SHEET NO.	
<b>STV Engineers, Inc.</b> <small>800 West Trade St., Suite 715 Charlotte, NC 28202 NC License Number F-0991</small>	

**SOIL STABILIZATION SUMMARY SHEET**

**MATTING FOR EROSION CONTROL  
(FOR SLOPE STABILIZATION)**

CONST SHEET NO.	LINE	FROM STATION	TO STATION	SIDE	ESTIMATE (SY)
			SUBTOTAL		375
	MISCELLANEOUS MATTING TO BE INSTALLED AS DIRECTED BY THE ENGINEER				38
				TOTAL	383
				SAY	385

**PERMANENT SOIL REINFORCEMENT MATTING  
(FOR DITCH STABILIZATION)**

CONST SHEET NO.	LINE	FROM STATION	TO STATION	SIDE	GEO FOR DRAINAGE ESTIMATE (SY)
4	-L- V-DITCH	13+50	14+05	RT	45
4	-L- V-DITCH	14+51	15+50	RT	75
			SUBTOTAL		120
	MISCELLANEOUS MATTING TO BE INSTALLED AS DIRECTED BY THE ENGINEER				12
				TOTAL	132
				SAY	135



PROJECT REFERENCE NO.	SHEET NO.
17BP10.R.63	EC-3A
RW SHEET NO.	
 <b>STV Engineers, Inc.</b> 800 West Trade St., Suite 715 Charlotte, NC 28202 NC License Number F-0991	

# SOIL STABILIZATION REQUIREMENTS

Stabilization for this project shall comply with the time frame guidelines as specified by the NCG-010000 general construction permit effective August 3, 2011 issued by the North Carolina Department of Environment and Natural Resources Division of Water Quality. Temporary or permanent ground cover stabilization shall occur within 7 calendar days from the last land-disturbing activity, with the following exceptions in which temporary or permanent ground cover shall be provided in 14 calendar days from the last land-disturbing activity. Temporary and permanent ground cover stabilization shall be achieved in accordance with the provisions in this contract and as directed.

<i>SITE DESCRIPTION</i>	<i>STABILIZATION TIME</i>	<i>TIMEFRAME EXCEPTIONS</i>
PERIMETER DIKES, SWALES, DITCHES AND SLOPES	7 DAYS	NONE
HIGH QUALITY WATER (HQW) ZONES	7 DAYS	NONE
SLOPES STEEPER THAN 3:1	7 DAYS	IF SLOPES ARE 10' OR LESS IN LENGTH AND ARE NOT STEEPER THAN 2:1, 14 DAYS ARE ALLOWED.
SLOPES 3:1 OR FLATTER	14 DAYS	7 DAYS FOR SLOPES GREATER THAN 50' IN LENGTH.
ALL OTHER AREAS WITH SLOPES FLATTER THAN 4:1	14 DAYS	NONE, EXCEPT FOR PERIMETERS AND HQW ZONES.

BRIDGE #830170  
SCALE: 1"=20'

CLEARING AND GRUBBING  
EROSION CONTROL FOR  
CONSTRUCTION SHEET 4

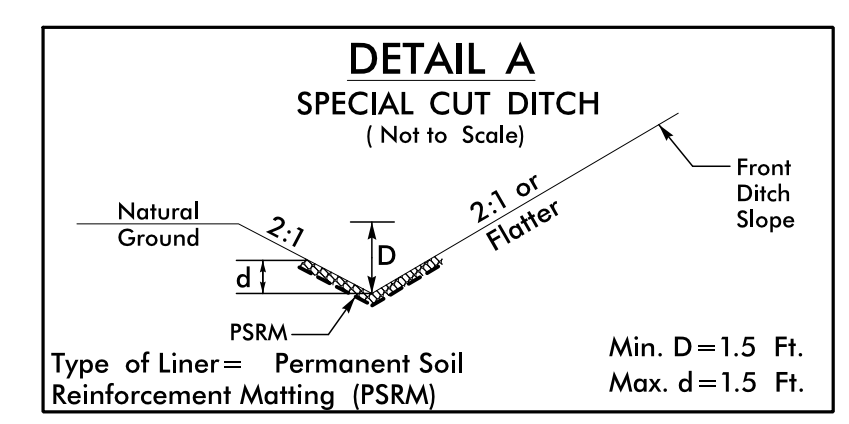
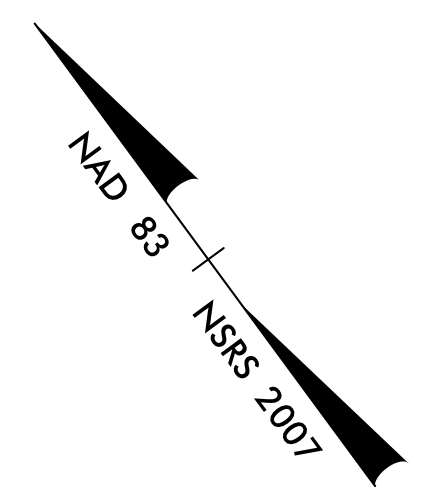

FROM STA. 13+50 TO STA. 14+05 RT  
FROM STA. 14+50 TO STA. 15+50 RT

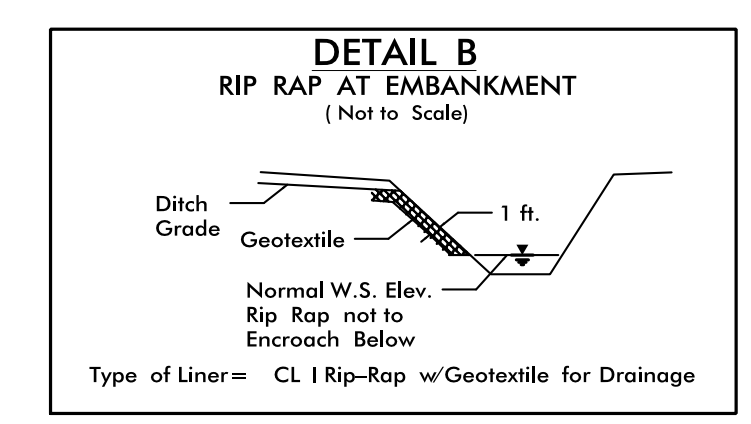

STA. 14+05 TO STA. 14+10 RT - 2TN CL-I, 3SY GEOTEXTILE  
STA. 14+35 TO STA. 14+50 RT - 5TN CL-I, 9SY GEOTEXTILE

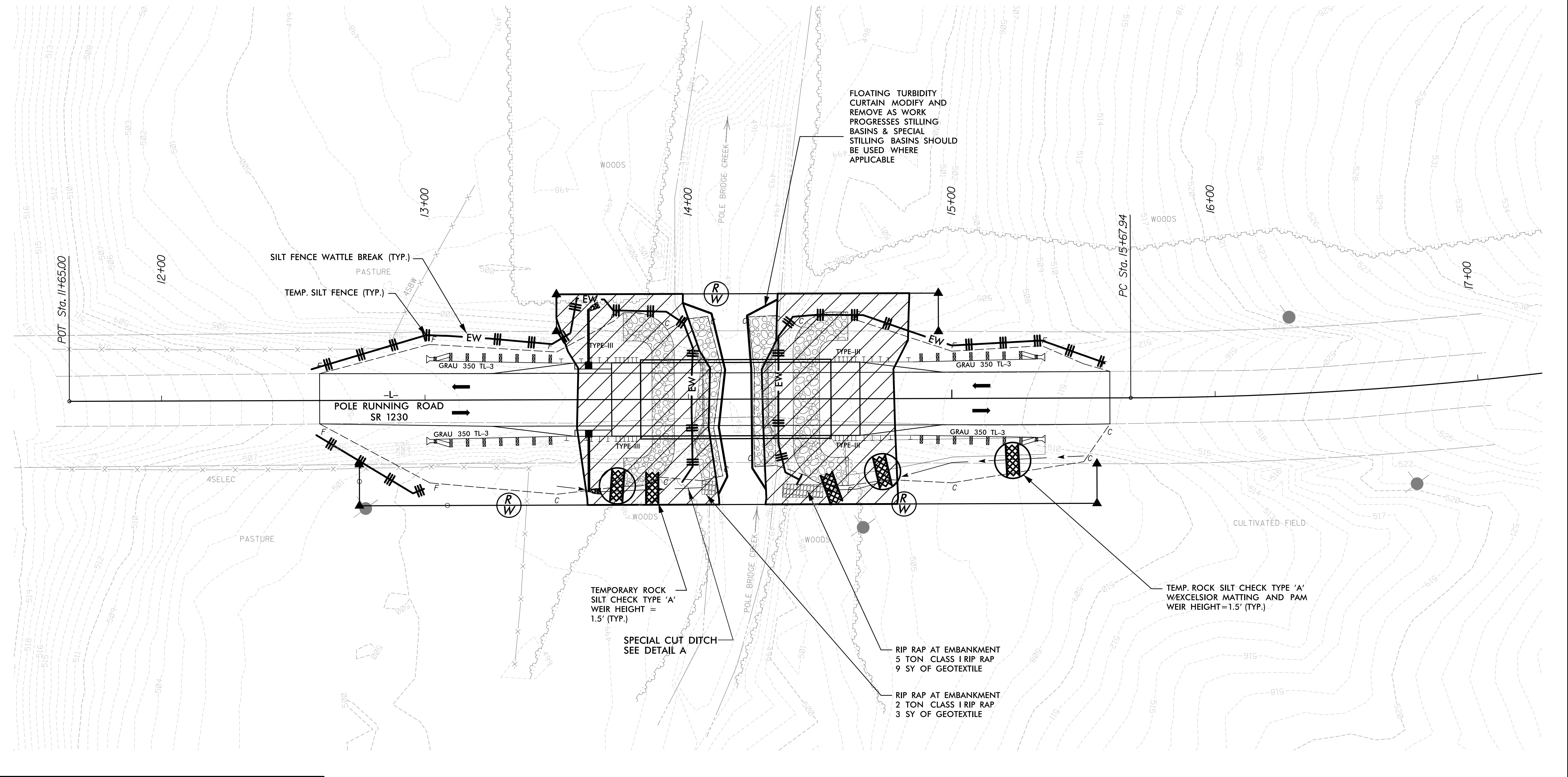

FLOATING TURBIDITY CURTAIN MODIFY AND REMOVE AS WORK PROGRESSES STILLING BASINS & SPECIAL STILLING BASINS SHOULD BE USED WHERE APPLICABLE

SILT FENCE WATTLE BREAK (TYP.)  
TEMP. SILT FENCE (TYP.)

TEMPORARY ROCK SILT CHECK TYPE 'A' WEIR HEIGHT = 1.5' (TYP.)

SPECIAL CUT DITCH SEE DETAIL A

RIP RAP AT EMBANKMENT 5 TON CLASS I RIP RAP 9 SY OF GEOTEXTILE

RIP RAP AT EMBANKMENT 2 TON CLASS I RIP RAP 3 SY OF GEOTEXTILE

TEMP. ROCK SILT CHECK TYPE 'A' WEXCELSIOR MATTING AND PAM WEIR HEIGHT=1.5' (TYP.)

NOTES: ANY DEVIATION FROM OPTIONS GIVEN WILL REQUIRE PRIOR APPROVAL BY ENGINEER.

ADDITIONAL EROSION CONTROL DEVICES MAY NEED TO BE INSTALLED AS DIRECTED BY THE ENGINEER.

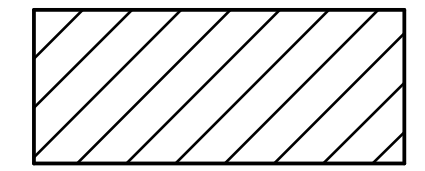

ENVIRONMENTALLY SENSITIVE AREA SEE PROJECT SPECIAL PROVISIONS

NOTE: PLACE TEMPORARY ROCK SEDIMENT DAMS TYPE-B AND TEMPORARY ROCK SILT CHECKS TYPE-A AT DRAINAGE OUTLETS

NOTE: UTILIZE SPECIAL STILLING BASIN AS STILLING BASIN WHERE APPLICABLE

NOTE: INSTALL FLOATING TURBIDITY CURTAIN AS DIRECTED

INSTALL PERMANENT DITCHES DURING C&G PHASE



BRIDGE #830170  
SCALE: 1"=20'

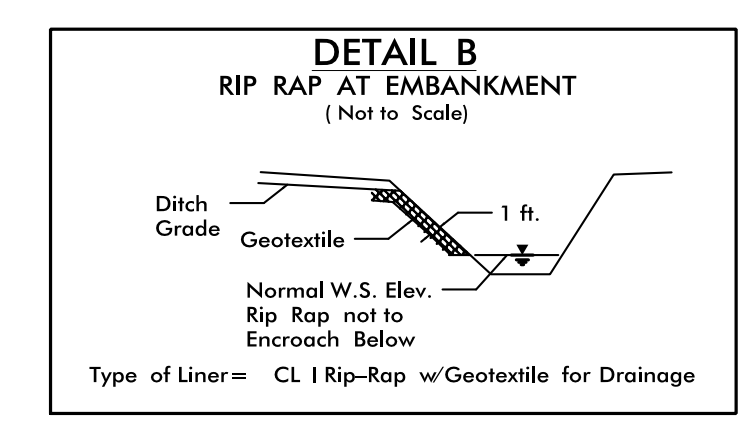
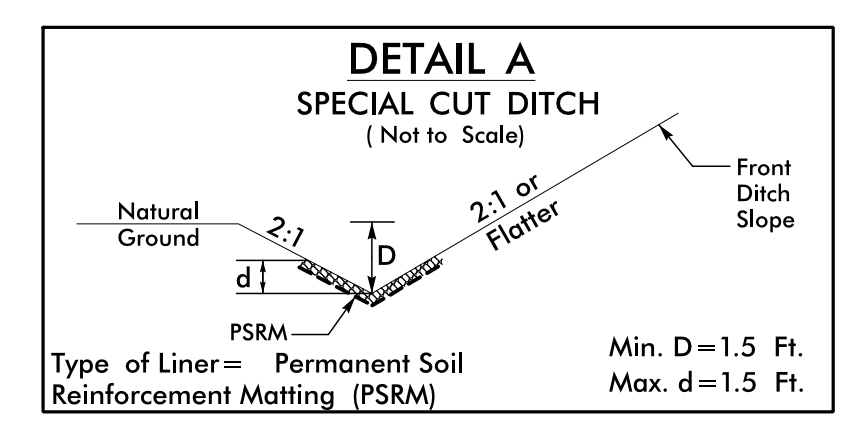
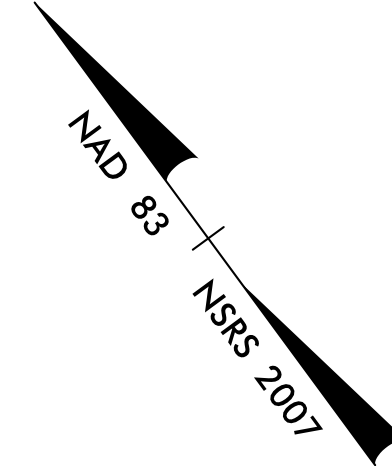

FROM STA. 13+50 TO STA. 14+05 RT  
FROM STA. 14+50 TO STA. 15+50 RT

STA. 14+05 TO STA. 14+10 RT - 2TN CL-1, 3SY GEOTEXTILE  
STA. 14+35 TO STA. 14+50 RT - 5TN CL-1, 9SY GEOTEXTILE

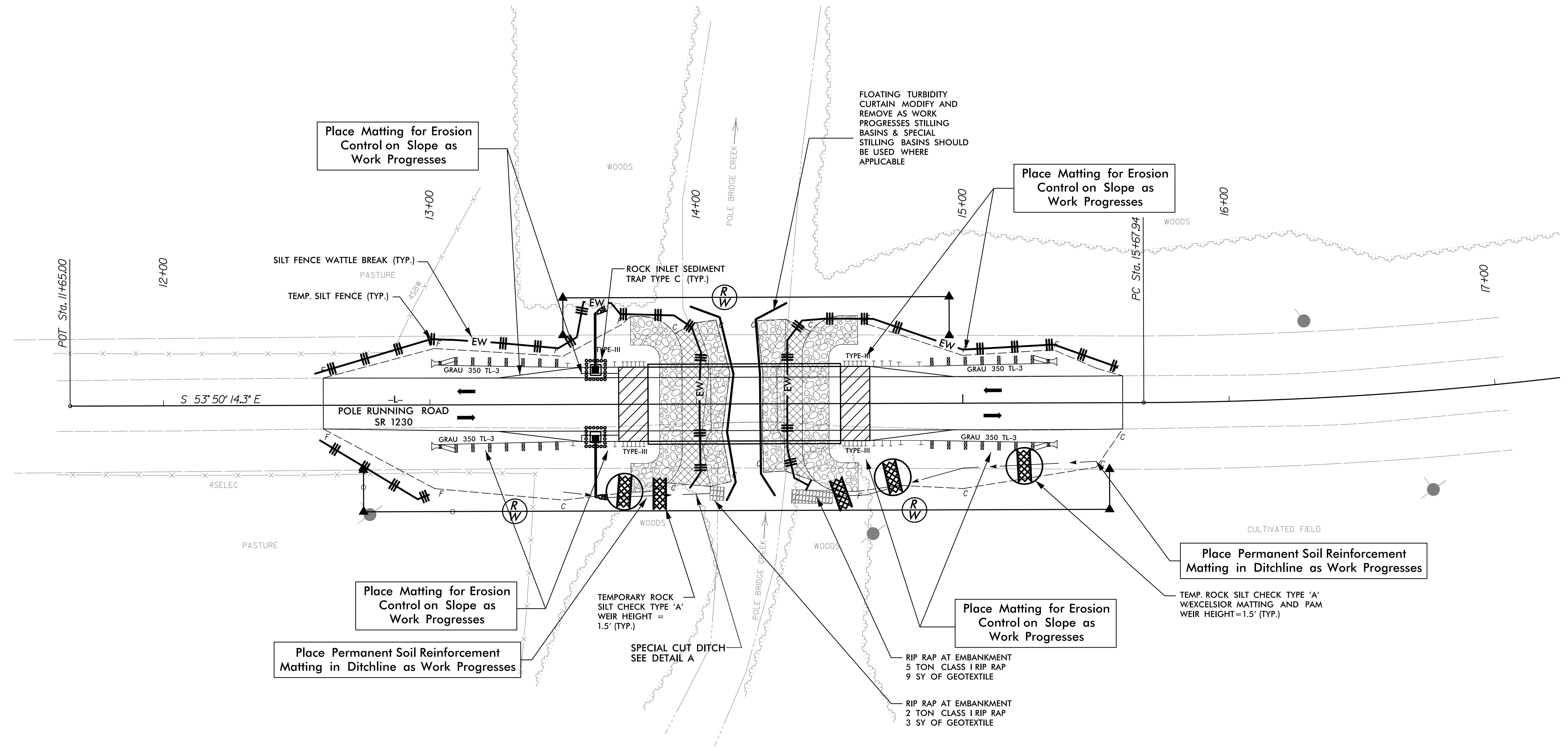

NOTES: ANY DEVIATION FROM OPTIONS GIVEN WILL REQUIRE PRIOR APPROVAL BY ENGINEER.

ADDITIONAL EROSION CONTROL DEVICES MAY NEED TO BE INSTALLED AS DIRECTED BY THE ENGINEER.

NOTE: UTILIZE SPECIAL STILLING BASIN AS STILLING BASIN WHERE APPLICABLE

NOTE: INSTALL FLOATING TURBIDITY CURTAIN AS DIRECTED

8/21/2015  
F:\Roadway\Proj\EC\10R63\_rdy\_psh\_EC05.dgn  
ClevessP

STATE	STATE PROJECT REFERENCE NO.	SHEET NO.	TOTAL SHEETS
N.C.	17BP.10.R.63	RF-1	1
STATE PROJ. NO.	F.A. PROJ. NO.	DESCRIPTION	
17BP.10.R.63		P.E.	
17BP.10.R.63		R/W & UTILITIES	
17BP.10.R.63		CONSTRUCTION	

## PLANTING DETAILS

### SEEDLING / LINER BAREROOT PLANTING DETAIL

#### HEALING IN

1. Locate a healing-in site in a shady, well protected area.
2. Excavate a flat bottom trench 12 inches deep and provide drainage.

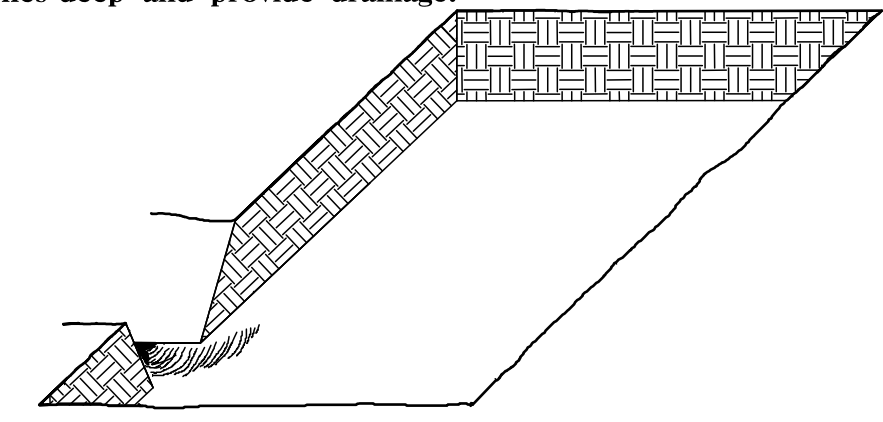

3. Backfill the trench with 2 inches well rotted sawdust. Place a 2 inch layer of well rotted sawdust at a sloping angle at one end of the trench.

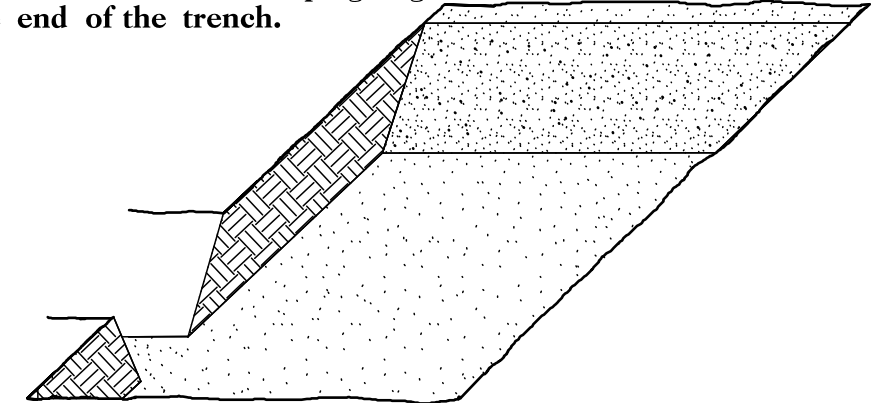

4. Place a single layer of plants against the sloping end so that the root collar is at ground level.

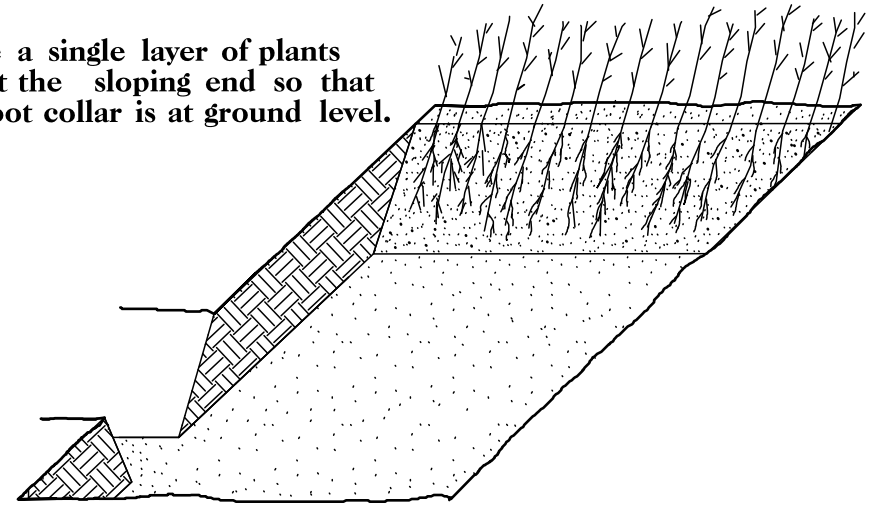

5. Place a 2 inch layer of well rotted sawdust over the roots maintaining a sloping angle.

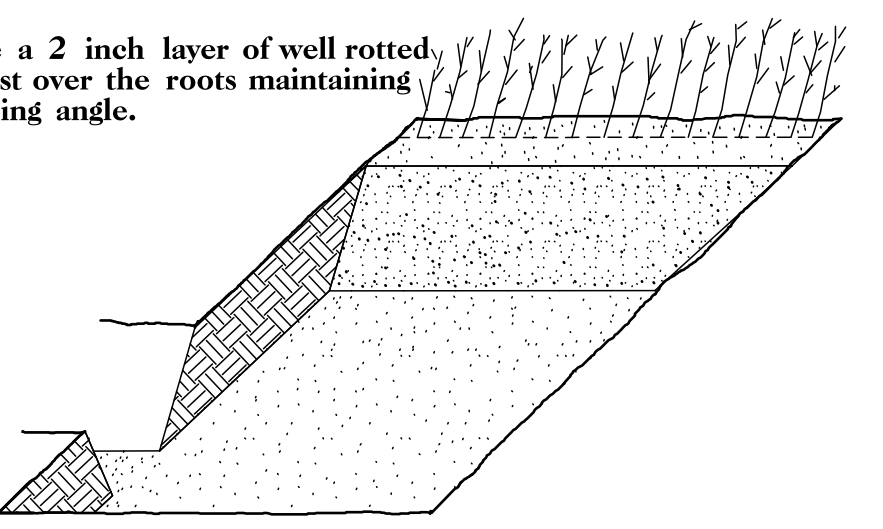

6. Repeat layers of plants and sawdust as necessary and water thoroughly.

#### DIBBLE PLANTING METHOD USING THE KBC PLANTING BAR

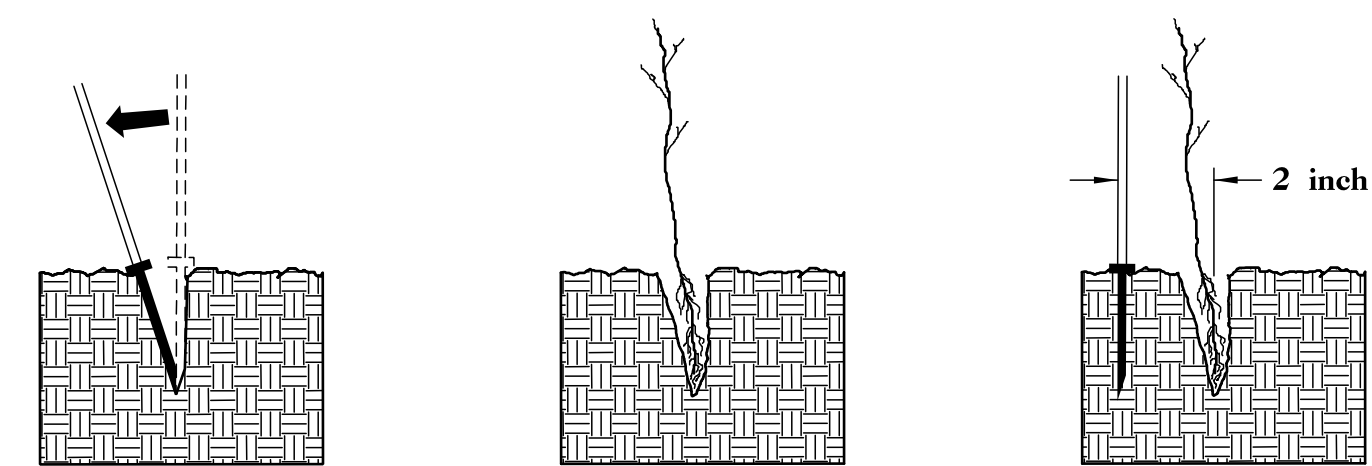

1. Insert planting bar as shown and pull handle toward planter.
2. Remove planting bar and place seedling at correct depth.
3. Insert planting bar 2 inches toward planter from seedling.

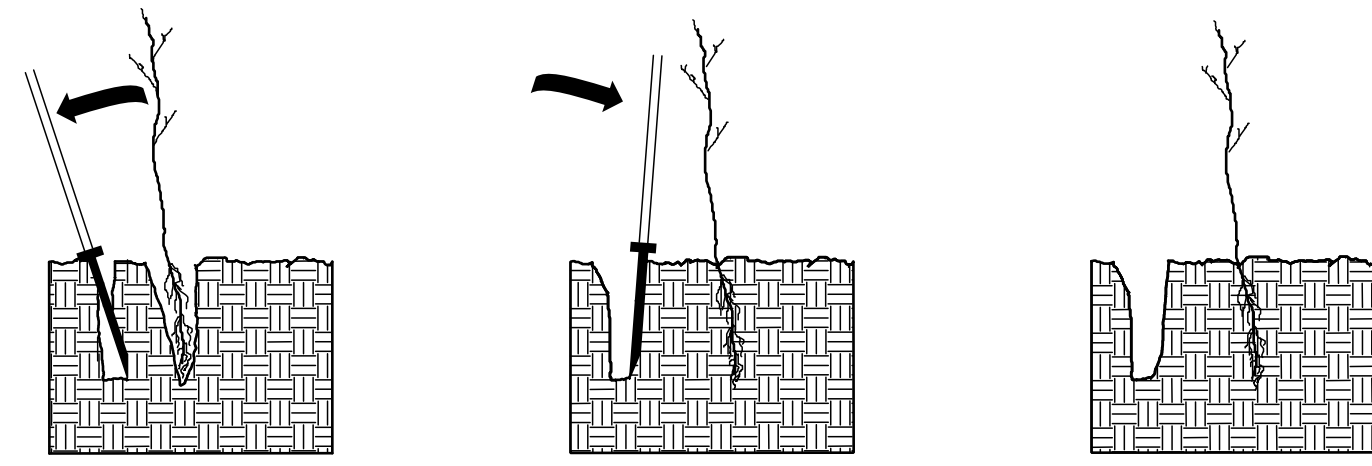

4. Pull handle of bar toward planter, firming soil at bottom.
5. Push handle forward firming soil at top.
6. Leave compaction hole open. Water thoroughly.

#### PLANTING NOTES:

**PLANTING BAG**  
During planting, seedlings shall be kept in a moist canvas bag or similar container to prevent the root systems from drying.

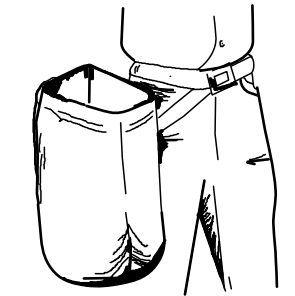

**KBC PLANTING BAR**  
Planting bar shall have a blade with a triangular cross section, and shall be 12 inches long, 4 inches wide and 1 inch thick at center.

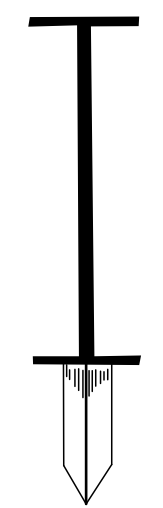

**ROOT PRUNING**  
All seedlings shall be root pruned, if necessary, so that no roots extend more than 10 inches below the root collar.

## REFORESTATION

- ☐ TREE REFORESTATION SHALL BE PLANTED 6 FT. TO 10 FT. ON CENTER, RANDOM SPACING, AVERAGING 8 FT. ON CENTER, APPROXIMATELY 680 PLANTS PER ACRE.

#### REFORESTATION

MIXTURE, TYPE, SIZE, AND FURNISH SHALL CONFORM TO THE FOLLOWING:

25%	LIRIODENDRON TULIPIFERA	TULIP POPLAR	12 in - 18 in BR
25%	PLATANUS OCCIDENTALIS	SYCAMORE	12 in - 18 in BR
25%	FRAXINUS PENNSYLVANICA	GREEN ASH	12 in - 18 in BR
25%	BETULA NIGRA	RIVER BIRCH	12 in - 18 in BR

## REFORESTATION DETAIL SHEET

N.C.D.O.T. - ROADSIDE ENVIRONMENTAL UNIT



**PROJECT WBS: 17BP.10.R.63**

**CONTRACT:**

STATE OF NORTH CAROLINA  
DIVISION OF HIGHWAYS

PROJECT NO.	SHEET NO.
17BP.10.R.63	UO-1

# UTILITIES BY OTHERS PLANS STANLY COUNTY

**LOCATION: BRIDGE #170 OVER POLE BRANCH CREEK  
ON SR 1230 (POLE RUNNING RD.)**

**TYPE OF WORK: AERIAL POWER AND TELEPHONE**

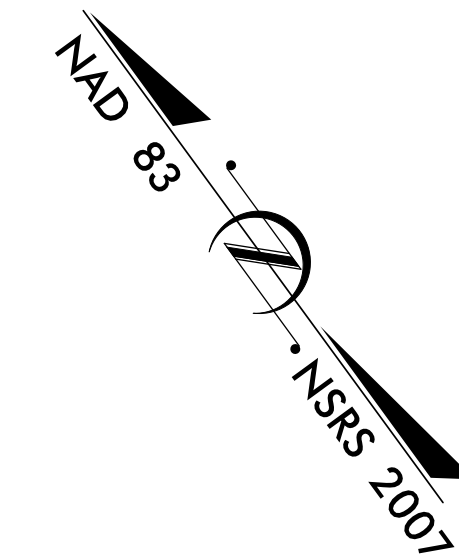
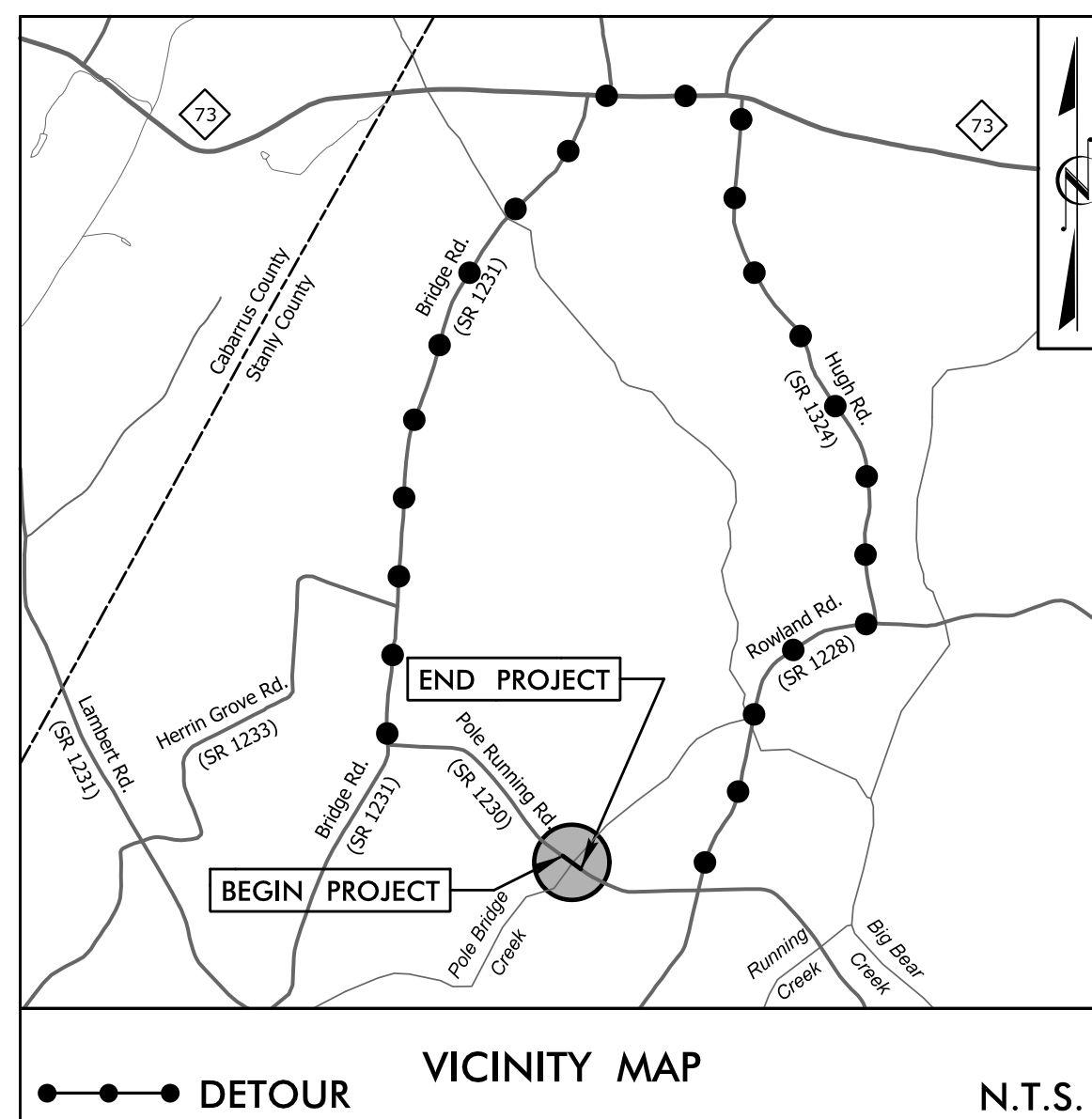

**BEGIN PROJECT WBS 17BP.10.R.63**  
-L- STA. 12 + 60.00

**END PROJECT WBS 17BP.10.R.63**  
-L- STA. 15 + 60.00

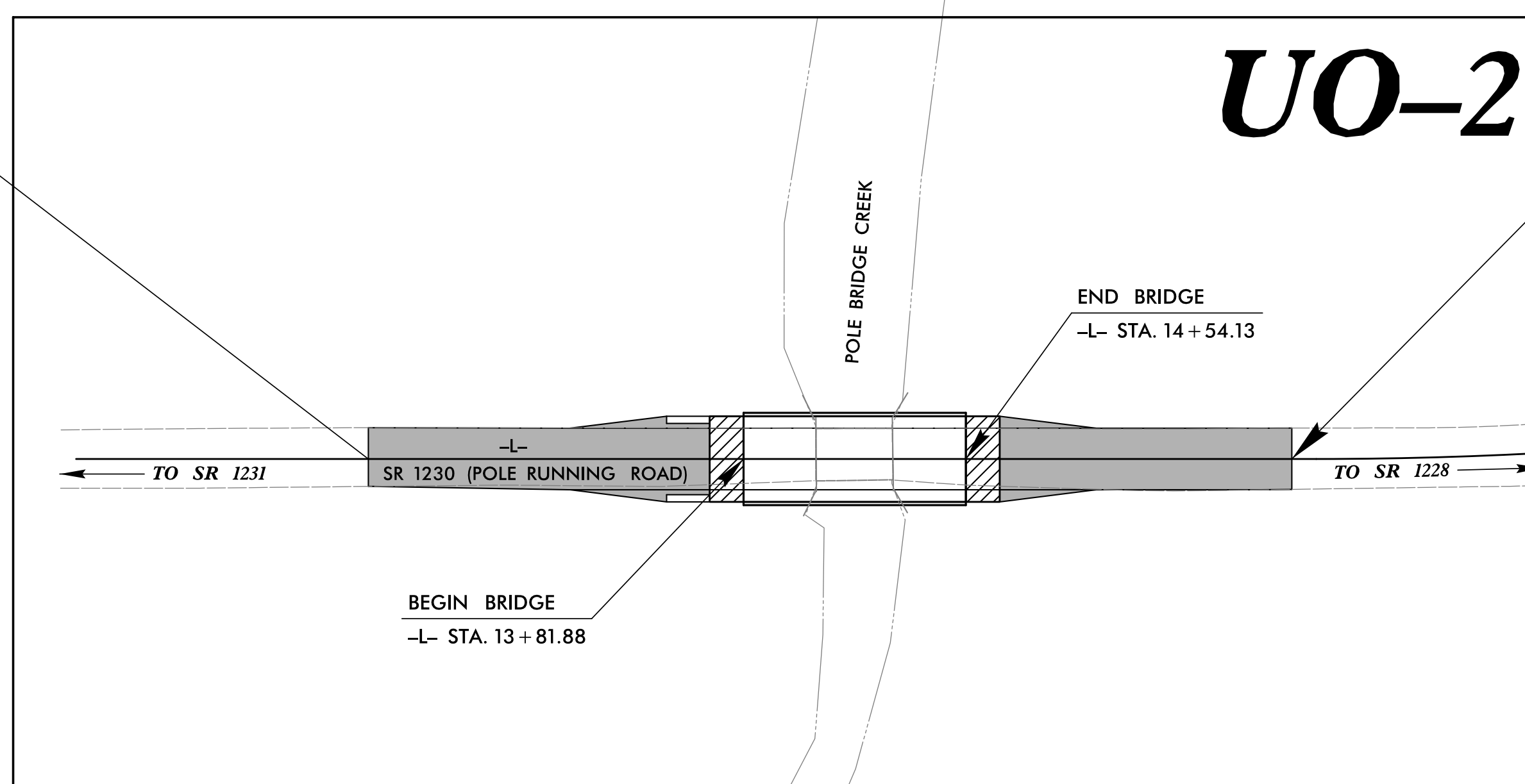

**GRAPHIC SCALES**

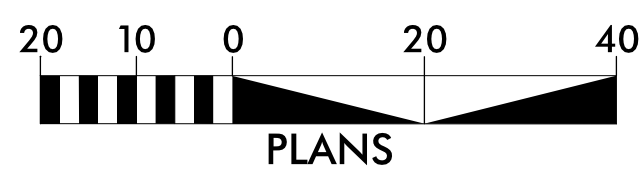

**INDEX OF SHEETS**

SHEET NO.	DESCRIPTION
UO-1	TITLE SHEET
UO-2	UTILITIES BY OTHERS PLANS

**UTILITY OWNERS ON PROJECT**

- (1) POWER - UNION POWER
- (2) TELEPHONE - WINDSTREAM

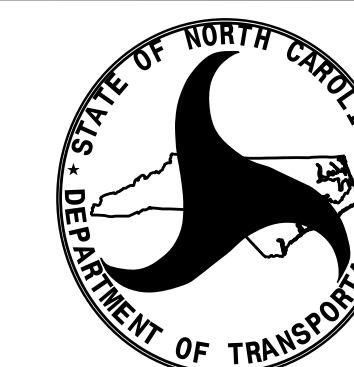

PREPARED FOR THE OFFICE OF:  
**DIVISION OF HIGHWAYS  
UTILITIES ENGINEERING  
SECTION**

1591 MAIL SERVICES CENTER  
RALEIGH, NC 27699-1591  
PHONE (919) 250-4128  
FAX (919) 250-4119

**Roger Worthington, P.E.** UTILITIES SECTION ENGINEER  
**Xxxxx Xxxxx, P.E.** UTILITIES SQUAD LEADER PROJECT ENGINEER  
**Reece Schuler, PE** UTILITIES PROJECT DESIGNER

### UTILITIES BY OTHERS

**NOTE:**  
ALL PROPOSED UTILITY WORK SHOWN ON THIS SHEET WILL BE DONE BY OTHERS

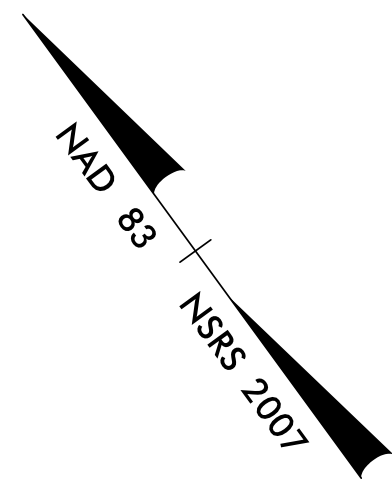

**V&M**  
Vaughn & Melton  
Consulting Engineers

Asheville, North Carolina 828-253-2196  
Tri-Cities, Tennessee 423-467-8401  
Knoxville, Tennessee 865-546-5800  
Middlesboro, Kentucky 606-248-6600  
Spartanburg, South Carolina 864-574-4775

Charlotte, North Carolina 704-357-0488

Copyright © 2006 Vaughn & Melton, Inc. All Rights Reserved.

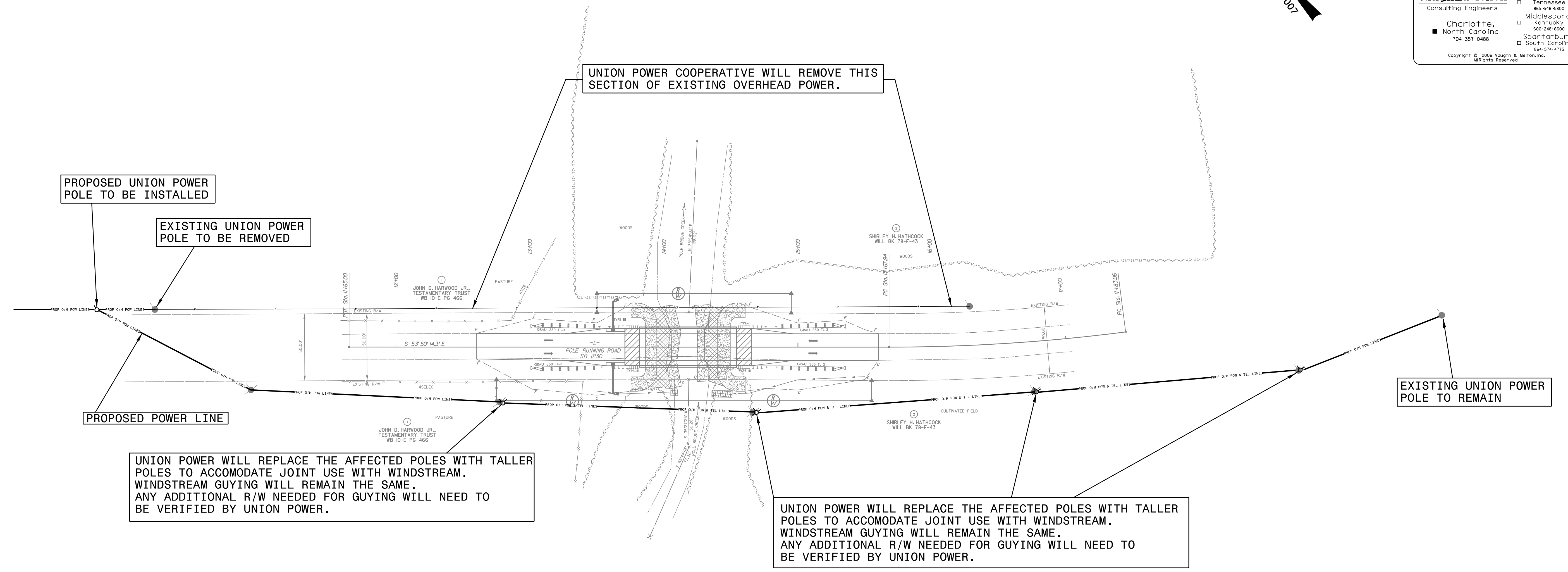

8/23/99

0 2.5 5	PROJ. REFERENCE NO.	SHEET NO.
	17BP.10.R.63	X-1

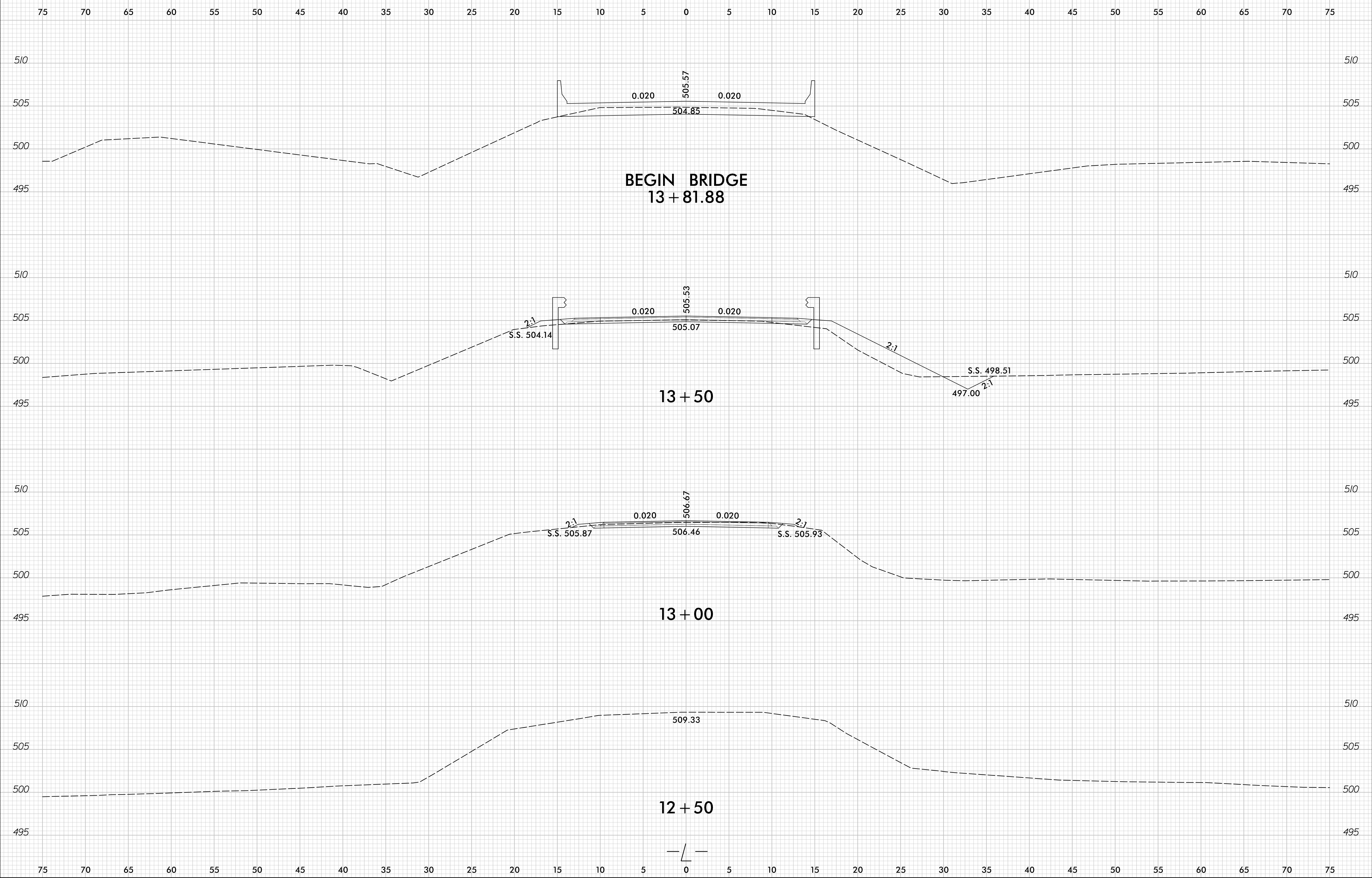

8/27/2015  
c:\proge\way\Xsc\10R63\_rdu.xpl.L.dgn  
C:\Users\...



8/23/99

0 2.5 5	PROJ. REFERENCE NO.	SHEET NO.
	17BP.10.R.63	X-2

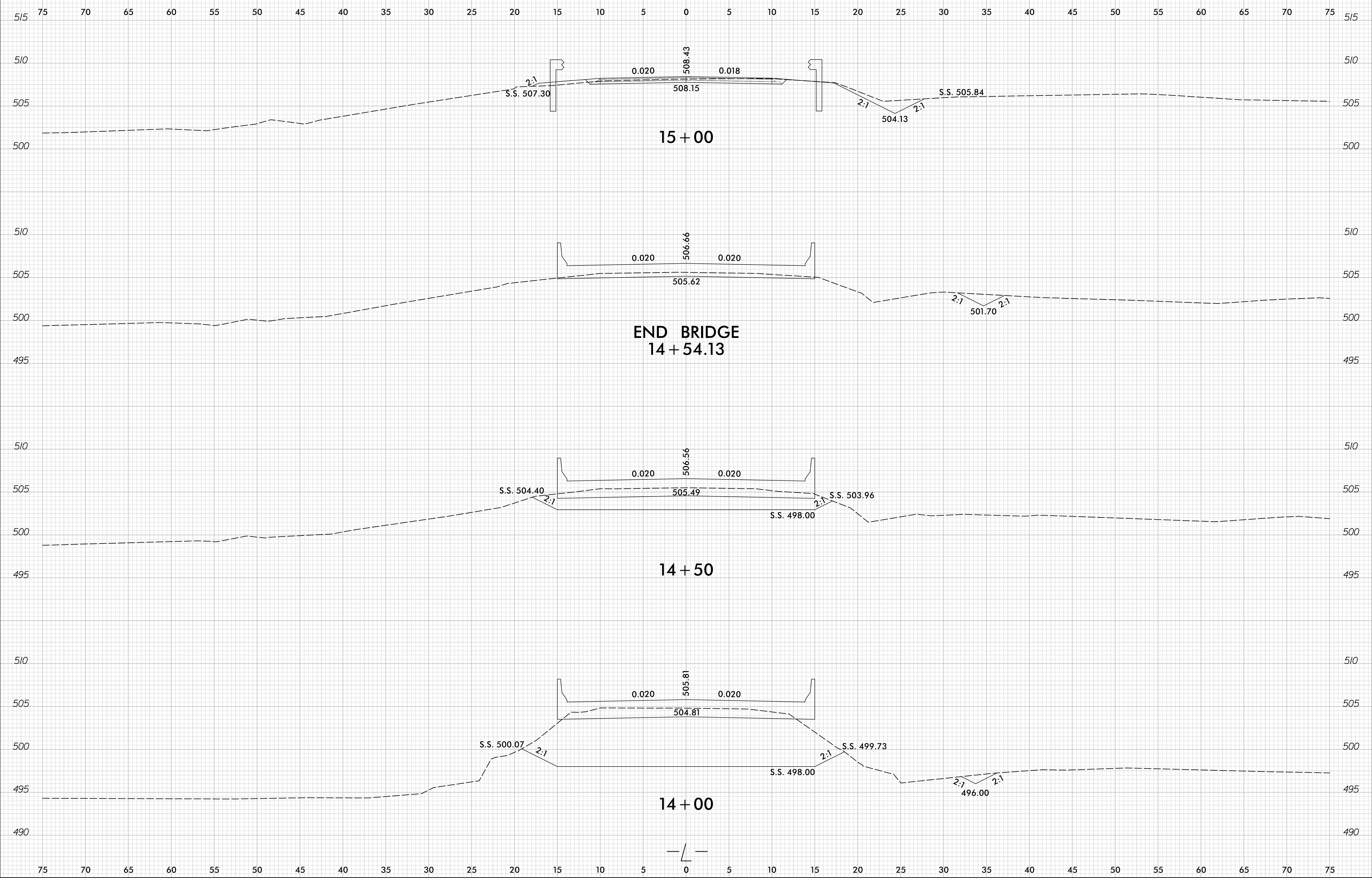

8/27/2015  
c:\progr\way\Xsc\10R63\_rdu\_xpl.L.dgn  
C:\Users\...

8/23/99

0 2.5 5	PROJ. REFERENCE NO.	SHEET NO.
	17BP.10.R.63	X-3

75 70 65 60 55 50 45 40 35 30 25 20 15 10 5 0 5 10 15 20 25 30 35 40 45 50 55 60 65 70 75

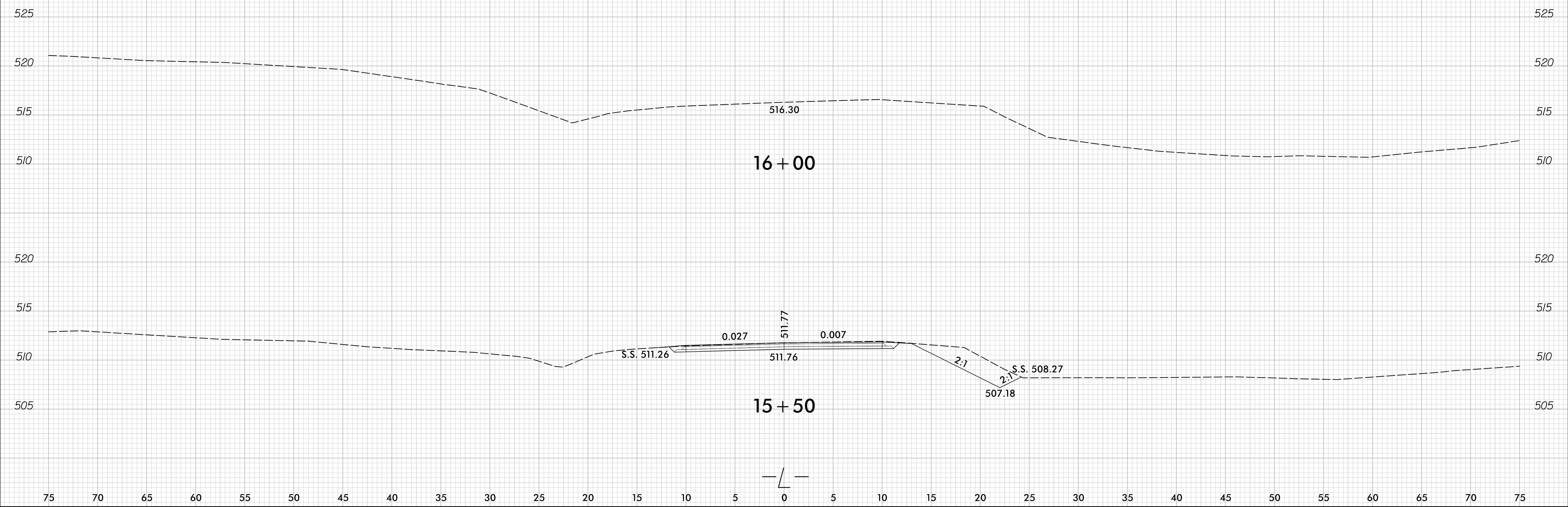

8/27/2015  
C:\ProgeWay\Xsc\10R63\_rdu\_xpl.dgn  
C:\Users

75 70 65 60 55 50 45 40 35 30 25 20 15 10 5 0 5 10 15 20 25 30 35 40 45 50 55 60 65 70 75